

# SC10.3

#7081 Lucas Oil SC10.3 RTR  
#7082 AE Team SC10.3 RTR

*Ready-To-Run*

1:10 Scale Electric 2WD Off Road Race Truck Manual & Catalog



## :: Introduction

Thank you for purchasing this Team Associated product. This assembly manual contains instructions and tips for building and maintaining your new SC10.3 RTR Qualifier Series Vehicle. Please take a moment to read through this manual to help familiarize yourself with these steps.

We are continually changing and improving our designs; therefore, actual parts may appear slightly different than in the illustrations. New parts will be noted on supplementary sheets located in the appropriate parts bags. Check each bag for these sheets before you start to build.

## :: KIT Features

Features in the SC10.3 RTR Qualifier Series Vehicle:

- 2010 ROAR National Champion short course race truck
- 2.4GHz 2-channel radio system with a metal gear steering servo
- Brushless Electronic Speed Control
- Powerful Reedy Motor
- Water-Resistant enclosed receiver box
- Blue anodized V2 coil-over shocks with adjustable pre-load
- 2.6:1 ratio gearbox with heavy duty sealed gear differential and externally adjustable V2 slipper clutch
- KMC® replica hex-drive wheels front and rear
- Racing compound rear tires and inserts
- Short course racing truck body
- Realistic bumpers front and rear with AE logo mud flaps
- Molded battery hold-down strap fits NiMH & LiPo battery packs
- 14 precision rubber sealed ball bearings

## :: Additional

Your new SC10.3 RTR comes factory assembled including radio gear, motor, and ESC. However, there are some items you will need to complete your kit (refer to catalog section for suggestions):

- AA-size batteries for transmitter (#302 x4)
- Peak Detection Charger or LiPo Compatible Charger
- 6 cell NiMH battery pack or 2S LiPo battery pack w/High Current T Plug.

Tools included:

- Allen wrenches #6950 (.050", 1/16", 3/32", 5/64")
- 1.5mm allen wrench
- Molded tools (AE #6956)
- Camber gauge (AE #1719)

## :: Other Helpful Items

- Green Slime shock lube (AE # 1105)
- Thread Locking Compound (AE # 1596)
- Silicone Diff Fluid (Refer to catalog for complete listings)
- 8 Piece Hex Driver Set (AE # 1655)
- Hobby Knife
- Needle Nose Pliers
- Calipers or a Precision Ruler
- Reamer / Hole Punch
- FT Nut Drivers (AE #1663 - 1668, used with #1655 or 1656 handle)
- Cyanoacrylate glue (AE # 1597)
- Silicone Shock Fluid (Refer to catalog for complete listings)
- Body Scissors (AE # 1737)
- FT Hex Wrenches (AE # 1655)
- Wire Cutters
- Soldering Iron
- Ride Height Gauge (AE #1449)
- Turnbuckle Wrench (AE #1114)

**Associated Electrics, Inc.**  
**26021 Commercentre Dr.**  
**Lake Forest, CA 92630**



**Customer Service**  
**Tel: 949.544.7500**  
**Fax: 949.544.7501**

**:: Hardware - 1:1 Scale View**

**Cap Head (shcs)**

	<b>4-40 x 1/4 (6285)</b>
	<b>4-40 x 3/8 (6924)</b>
	<b>4-40 x 1/2 (6925)</b>
	<b>4-40 x 5/8 (6926)</b>
	<b>4-40 x 3/4 (6927)</b>
	<b>4-40 x 7/8 (7738)</b>
	<b>4-40 x 1 (6928)</b>
	<b>4-40 x 1 1/4 (6913)</b>
	<b>4-40 x 1 3/4 (9833)</b>
	<b>5-40 x 7/16 (9643)</b>
	<b>5-40 x 9/16 (9644)</b>
	<b>5-40 X 3/4 (9835)</b>

**Set Screws**

	<b>4-40 x 1/2 (9170)</b>
	<b>5-40 x 1/8 (3862)</b>

**Ball Bearings**

	<b>3/16 x 3/8 (3977)</b>
	<b>10 x 16mm (9832)</b>

**Diff Balls (for Optional Ball Diff)**

	<b>5/64 Diff Thrust Balls (6574)</b>
	<b>3/32 Carbide Diff Balls (6581)</b>
	<b>3/32 Ceramic Diff Balls (6584)</b>

**Flat Head (fhcs)**

	<b>2.5x6mm (4675)</b>
	<b>4-40 x 3/8 (6292)</b>
	<b>4-40 x 1/2 (6922)</b>
	<b>4-40 x 5/8 (6915)</b>
	<b>5-40 x 1/2 (9269)</b>

**Shims and Washers**

	<b>Ballstud Washer (9630)</b>
	<b>.03 Nylon Washer (4187)</b>
	<b>Gold Washer (7337)</b>
	<b>3/16 Axle Shim (7368)</b>
#4 Aluminum Washer"/>	<b>#4 Aluminum Washer (6936)</b>
	<b>5 x 9.5mm Shim (9830)</b>
	<b>Gear Diff Outdrives</b>
	<b>Servo Saver Shim (9610)</b>
	<b>Servo Saver Hardware (lower)</b>
	<b>Servo Saver Shim (9610)</b>
	<b>Servo Saver Hardware (upper)</b>
	<b>0.5mm Shim (9888)</b>
	<b>Diff Rebuild</b>

**Button Head (bhcs)**

	<b>2-56 x 1/8 (9645)</b>
	<b>2-56 x 5/16 (4334)</b>
	<b>4-40 x 5/16 (6919)</b>
	<b>4-40 x 3/8 (6917)</b>
	<b>4-40 x 7/16 (2221)</b>
	<b>3x6mm (31531)</b> <b>Aluminum (8550)</b>
	<b>Titanium (91580)</b>

**Ballstuds**

	<b>Black .200" (3981)</b>
	<b>Black .300" (3983)</b>
	<b>Silver .200" (6276)</b>
	<b>Silver .300" (6277)</b>

**Nuts (lock/plain)**

	<b>4-40 Small Plain Nut (7260)</b>
	<b>3/16 Aluminum Locking Nut (4449)</b>
	<b>Shock Mount Nut (6472)</b>
	<b>4-40 Nut (6295)</b>
	<b>5-40 Lock Nut (6629)</b>
	<b>8-32 Lock Nut, Steel (6952)</b>
	<b>8-32 Low Profile Lock Nut, Steel (6953)</b>

**Notes:**

**:: Table of Contents**

1..... Cover	15 - 16.....Shocks Build (Bag F 1-6)
2..... Introduction	17 - 20.....Electronics Build (Bag G 1-8)
3.....1:1 Hardware "Fold Out"	21 - 22.....Wheels, Tires, and Body Build (Bag H 1-2)
4..... Table of Contents	22.....Final Adjustments
5 - 6.....Steering Rack Build (Bag A 1-5)	23 - 24.....Tuning Tips
6 - 9.....Steering Knuckle and Front Arms Build (Bag B 1-7)	25 - 33.....Catalog
9 - 11.....Transmission Build (Bag C 1-10)	34 - 35.....Notes / Contact Info
12 - 14.....Rear Arms, Brace, Shock Tower, Upper Plate, and Bumper Build (Bag D 1-6)	36..... Setup Sheet "Kit Setup"
14 - 15.....Rear Hubs Build (Bag E 1-6)	37..... Setup Sheet "Blank"
	38..... Back Cover

**:: Notes**

***This symbol indicates a special note or instruction in the manual.***



***This symbol indicates a Racers Tip.***



***Scanning this QR code will take you to Team Associated's Tech Tips videos. These videos will help you with your build and setup!***



***There is a 1:1 hardware foldout page in the front of the manual. To check the size of a part, line up your hardware with the correct drawing until you find the exact size. Each part in the foldout has a number assigned to it for ordering replacement parts.***

**Associated Electrics, Inc.  
26021 Commercentre Dr.  
Lake Forest, CA 92630**



**Customer Service  
Tel: 949.544.7500  
Fax: 949.544.7501**

**<http://www.TeamAssociated.com> • <http://www.RC10.com> • [http://twitter.com/Team\\_Associated](http://twitter.com/Team_Associated) • <http://bit.ly/AEonFacebook>**

**:: Steering Rack Build - Bag A 2- Step 1**

**9610 Servo Saver Bolt**

**9610 Servo Saver Washer (Upper)**

**9659 Servo Saver (Lower)**

Remove bolt and washer; continue assembly per instructions.

**9610 Servo Saver Bolt**

**9610 Servo Saver Washer (Upper)**

**9659 Servo Saver (Lower)**

\*With supplied wrench, tighten servo saver bolt completely, until it hits bottom. Do not over tighten.

**:: Steering Rack Build - Bag A 2- Step 2**

**9659 Servo Saver (Upper)**

#6588 black grease

**9659 Servo Saver (Lower)**

**9657 Heavy Duty Servo Saver Spring**

**9610 Servo Saver Washer (Lower)**

**9610 Servo Saver Bolt**

**9610 Servo Saver Washer (Upper)**

\*With supplied wrench, tighten servo saver bolt completely, until it hits bottom. Do not over tighten.

**:: Steering Rack Build - Bag A 2/3- Step 3**

**6272 Dust Cover Foam**

**6276 Ball End, Short (Silver)**

**9659 Block Carrier Bushing**

**6272 Dust Cover Foam**

**6276 Ball End, Short (Silver)**

**9659 Bellcrank**

**2221 4-40x7/16 BHCS**

**:: Steering Rack Build - Bag A 4/5- Step 4**

**9566**  
Top Plate

**3856**  $\Sigma 4$   
Steering Rack Bushing

**9640**  
Steering Bolt (Right)

**9640**  
Steering Bolt (Left)

**9640**  
Steering Brace

**9640**  
Steering Bolt (Left)

**6925**  $\Sigma 2$   
4-40x1/2 SHCS

**9563**  
Front Bulkhead

**9823**  
SC10 Chassis

**6915**  $\Sigma 2$   
4-40x5/8 FHCS

**!**

\* Do Not overtighten steering bolts. Make sure there is free movement in the steering rack.

**:: Steering Knuckles Build - Bag B 2 - Step 1**

**6272**  
Dust Cover Foam

**4187**  $\Sigma 2$   
.030 Washer

**6277**  
Ball End, Long (Silver)

**3977**  
3/16x3/8 Bearing

**9881**  
Front Axle, Hex

**9882**  
C Clip (3/16")

**4449**  
4-40x3/16 Aluminum Locknut

**9880**  
Steering Block, Hex

**!**

\* Install the C Clip into the groove shown below.

**Build 2 (1 left, 1 right)**

**Build 2!**

**:: Steering Knuckles Build - Bag B 2 - Step 2**

**7368**  
3/16 Axle Shim

**3977**  
3/16x3/8 Bearing

**!**

\* Align the C clip on the front axles with the D-shape inside the steering blocks.

**9883**  
Wheel Hex Adapters

**7369**  
1/16" Universal Roll Pins

**Build 2 (1 left, 1 right)**

**:: Steering Knuckles Build - Bag B 2 - Step 3**

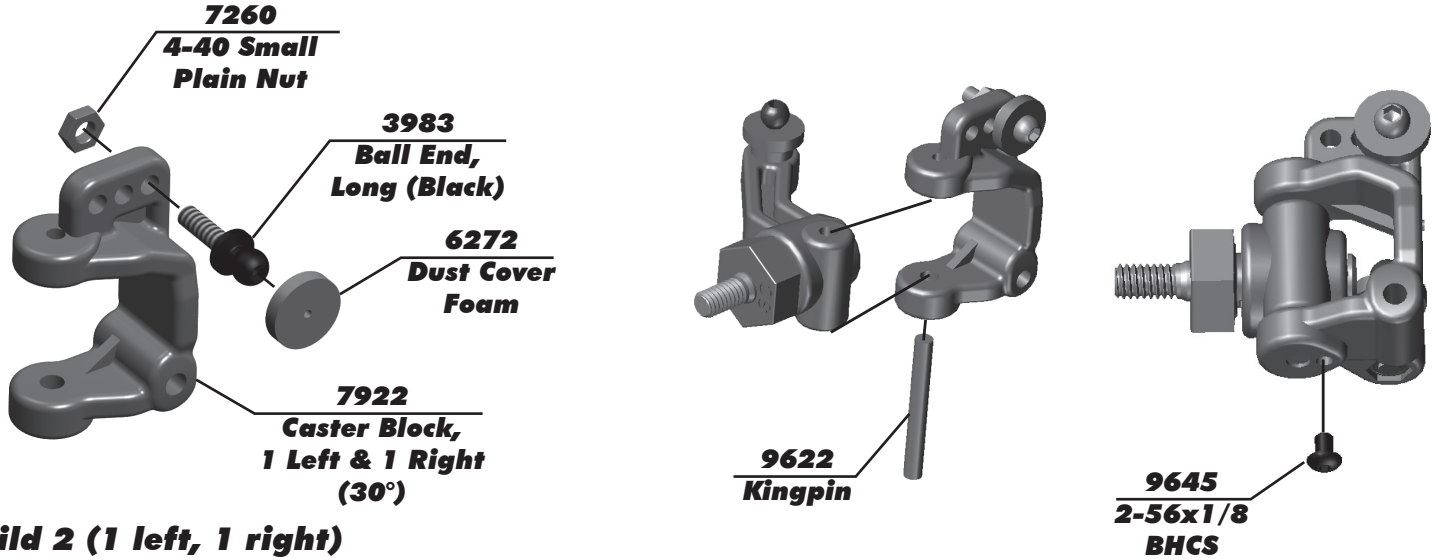

**Build 2 (1 left, 1 right)**

**:: Front Arms Build - Bag B 3 - Step 4**

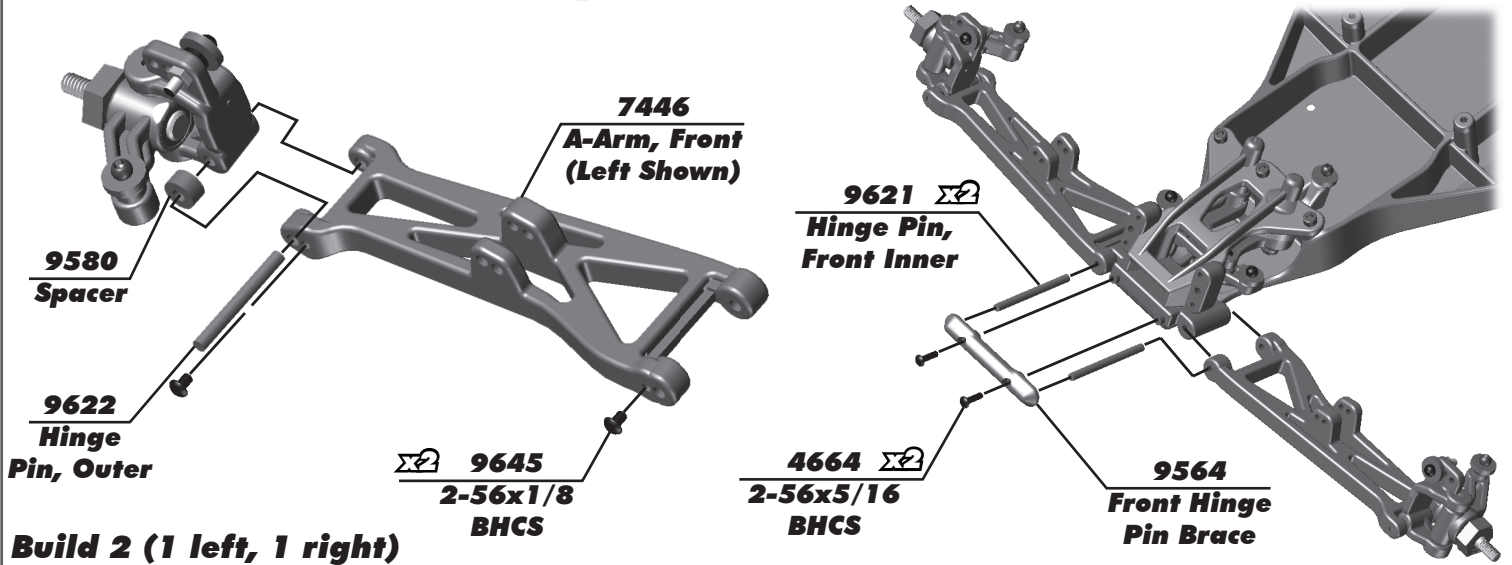

**Build 2 (1 left, 1 right)**

**:: Front Arms Build - Bag B 3 - Step 5**

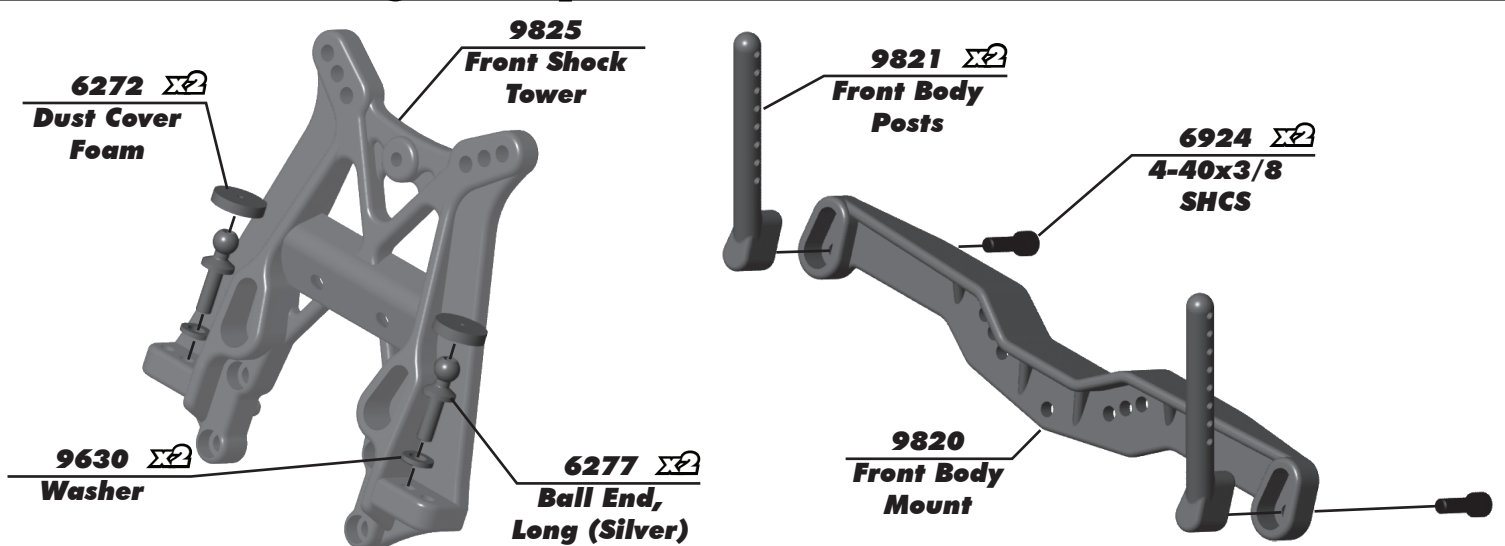

**:: Front Arms Build - Bag B 3 - Step 6**

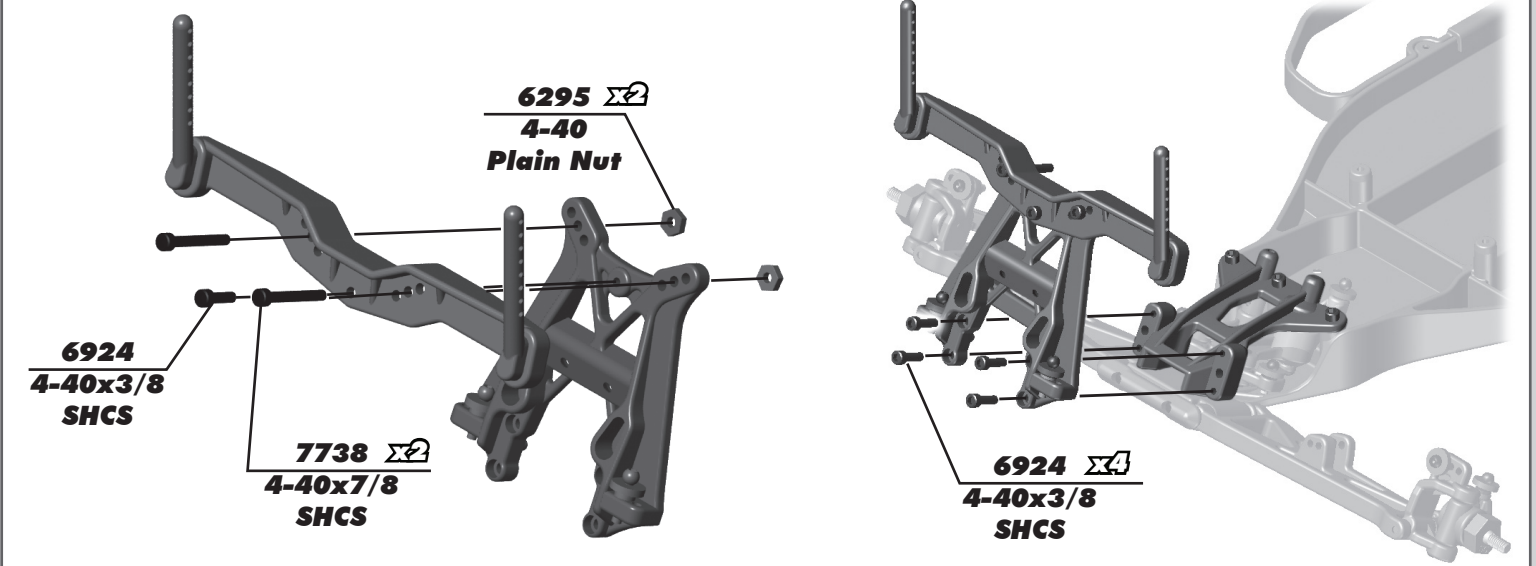

**:: Front Arms Build - Bag B 5 - Step 7**

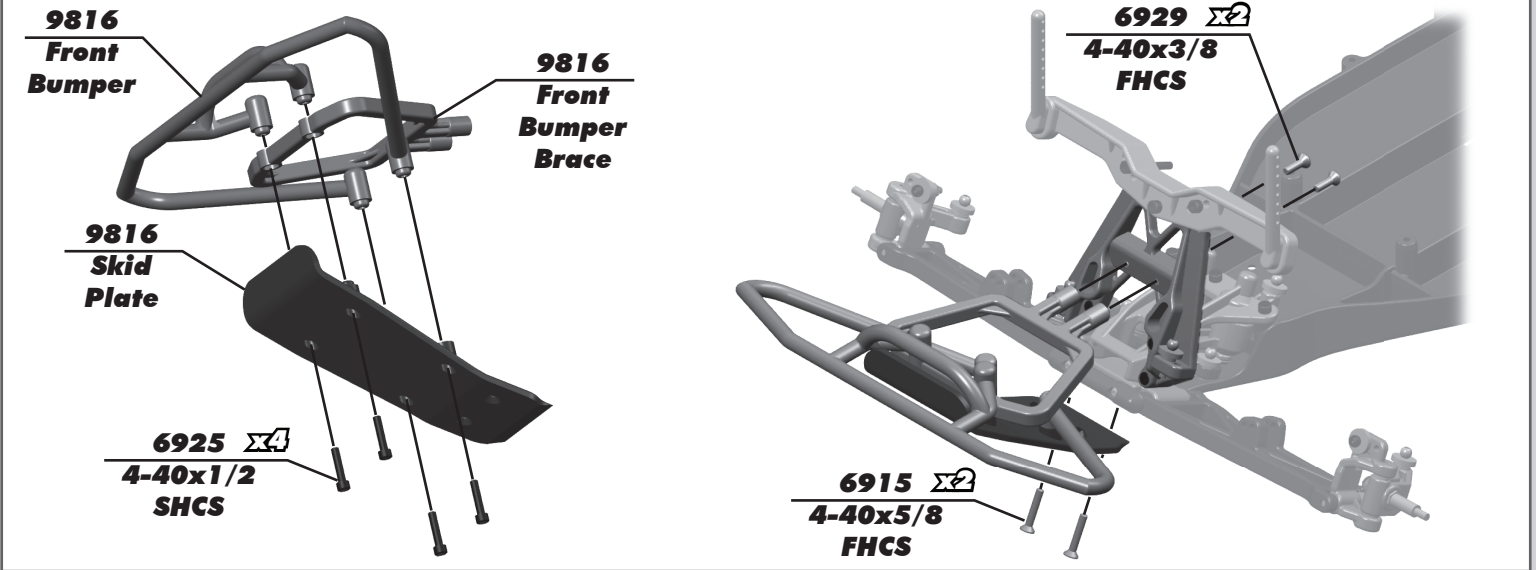

**:: Front Arms Build - Bag B 6 - Step 8**

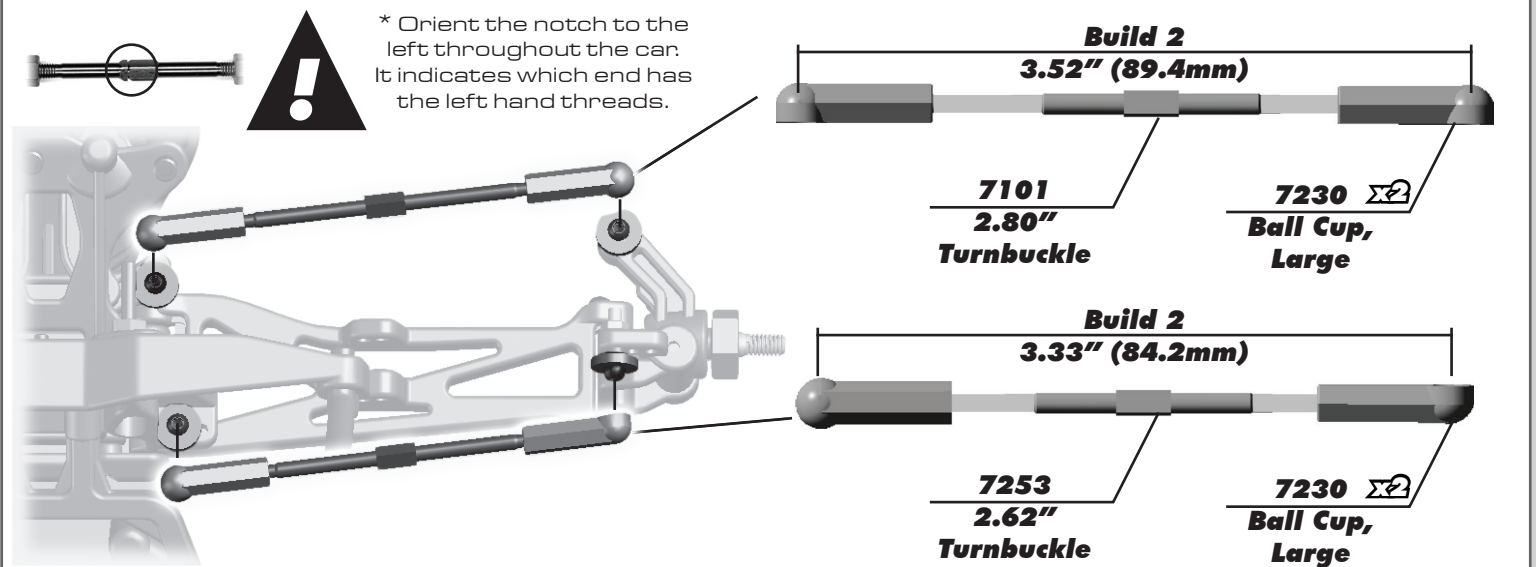



**:: Front Arms Build - Bag B 7 - Step 9**

**9822**  
**Nerf Bar,**  
**1 Left & 1 Right**

**6917**  $\Sigma 2$   
**4-40x3/8**  
**BHCS**

**!** \* Twist and flex side nerf guards into place!

**:: Transmission Build - Bag C 2 - Step 1**

**#6588**  
**black grease**

**9831**  
**3.6mmx0.7mm**  
**O-Ring**

**#6588**  
**black grease**

**9830**  
**Outdrive**  
**Cup**

**9828**  
**Diff Gear**  
**Cover**

**9888**  
**0.5mm Gear**  
**Diff Shim**

**9831**  
**4.7mmx1.42mm**  
**O-Ring**

**#6588**  
**black grease**

**:: Transmission Build - Bag C 2 / 3 - Step 2**

**9830**  
**2mm x 8mm**  
**Round End**  
**Pin**

**#6588**  
**black grease**

**9829**  
**Sun Gear**

**#6588**  
**black grease**

**9828**  
**Differential**  
**Gear, 52T 48P**

**!**

\* Align pin with groove in sun gear

**:: Transmission Build - Bag C 2 - Step 3**

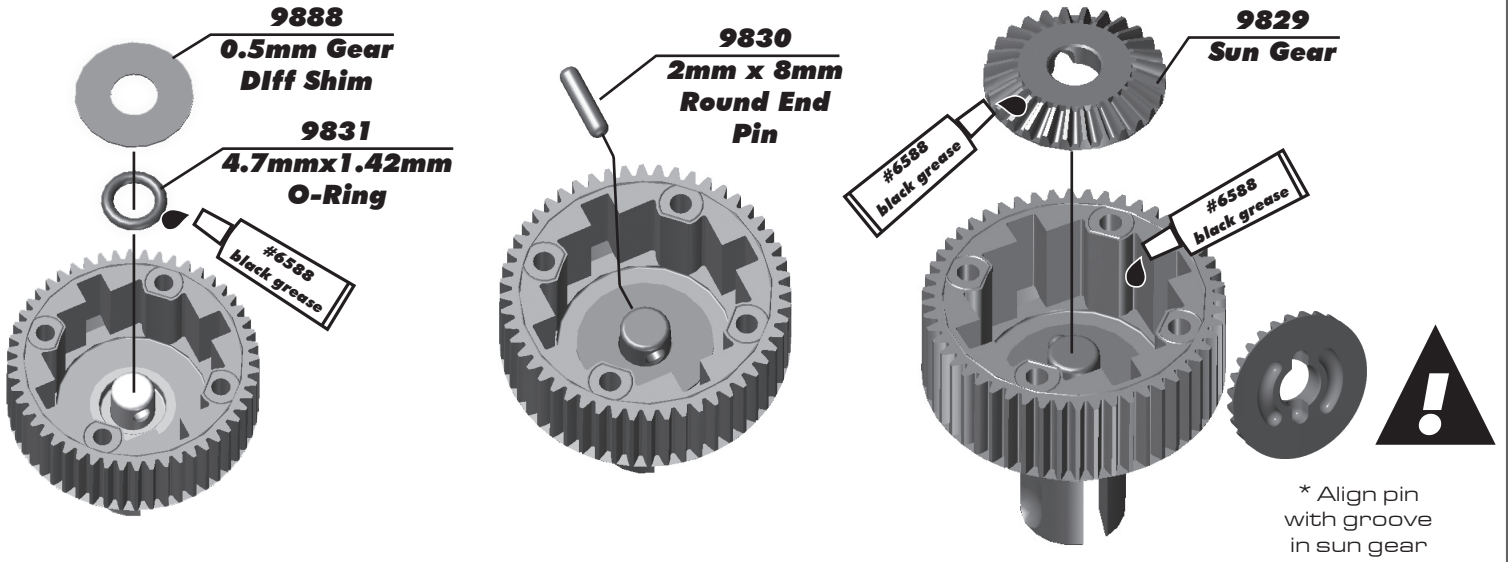

**:: Transmission Build - Bag C 2/4 - Step 4**

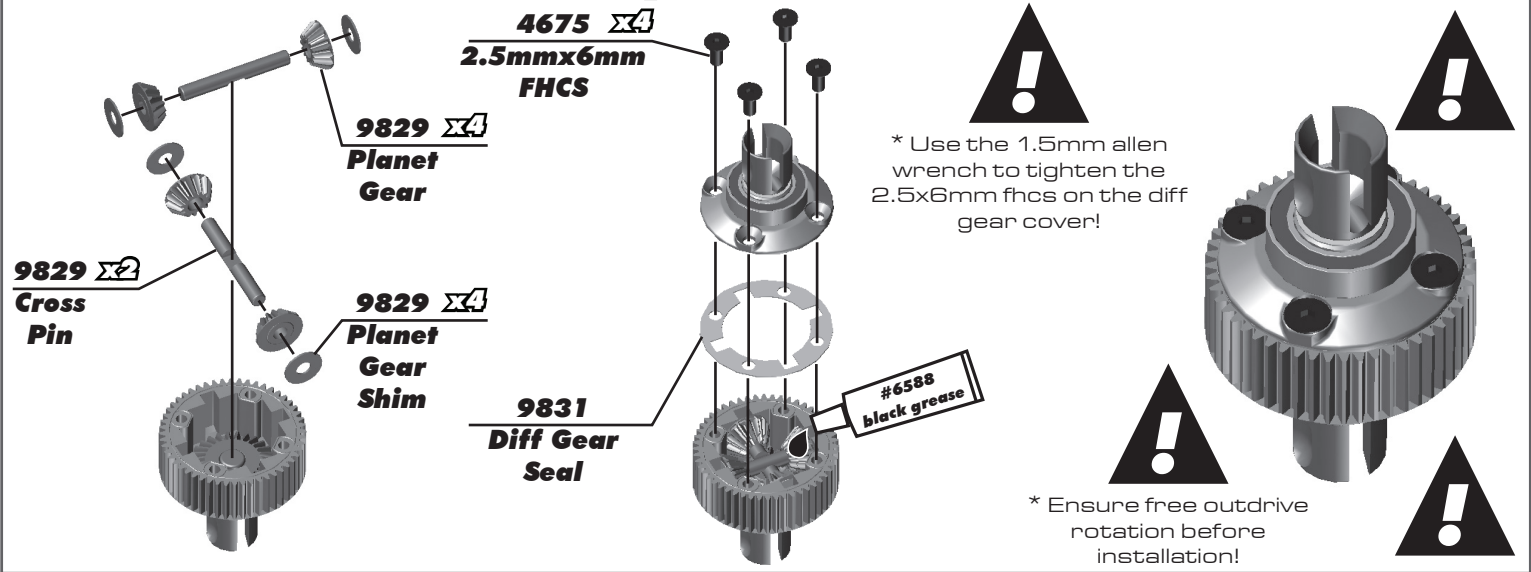

**:: Transmission Build - Bag C 5/6 - Step 5**

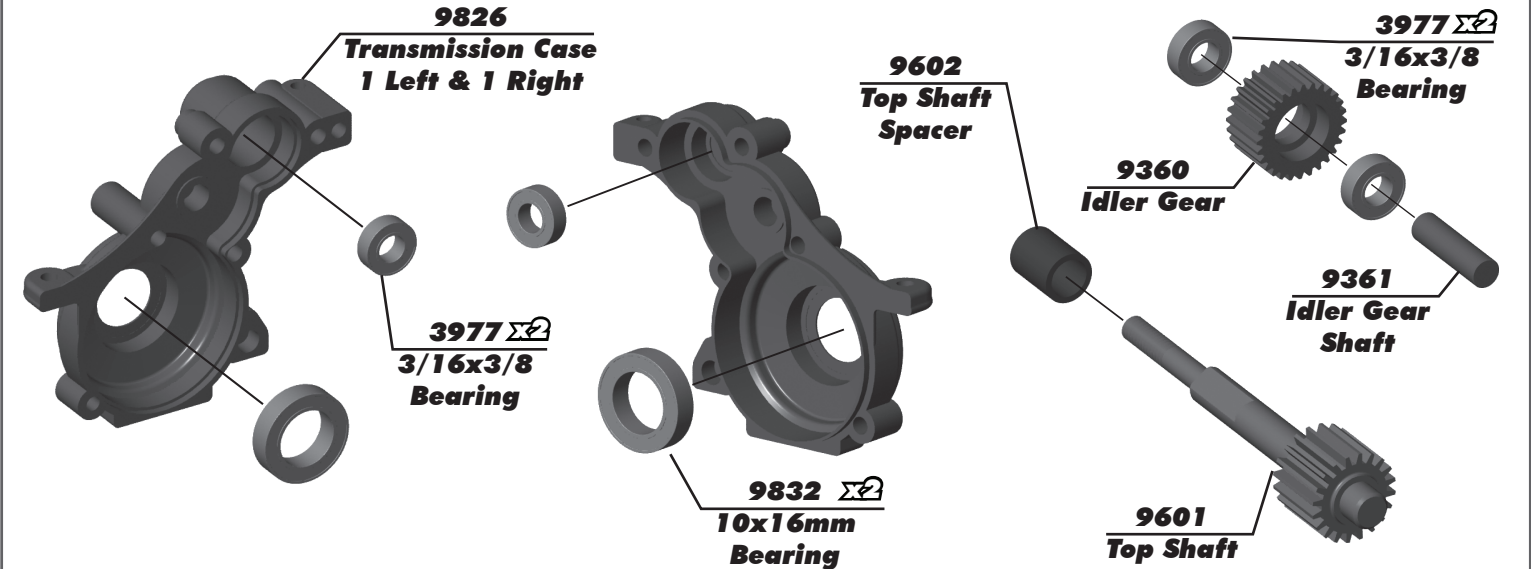

**:: Transmission Build - Bag C 7 - Step 6**

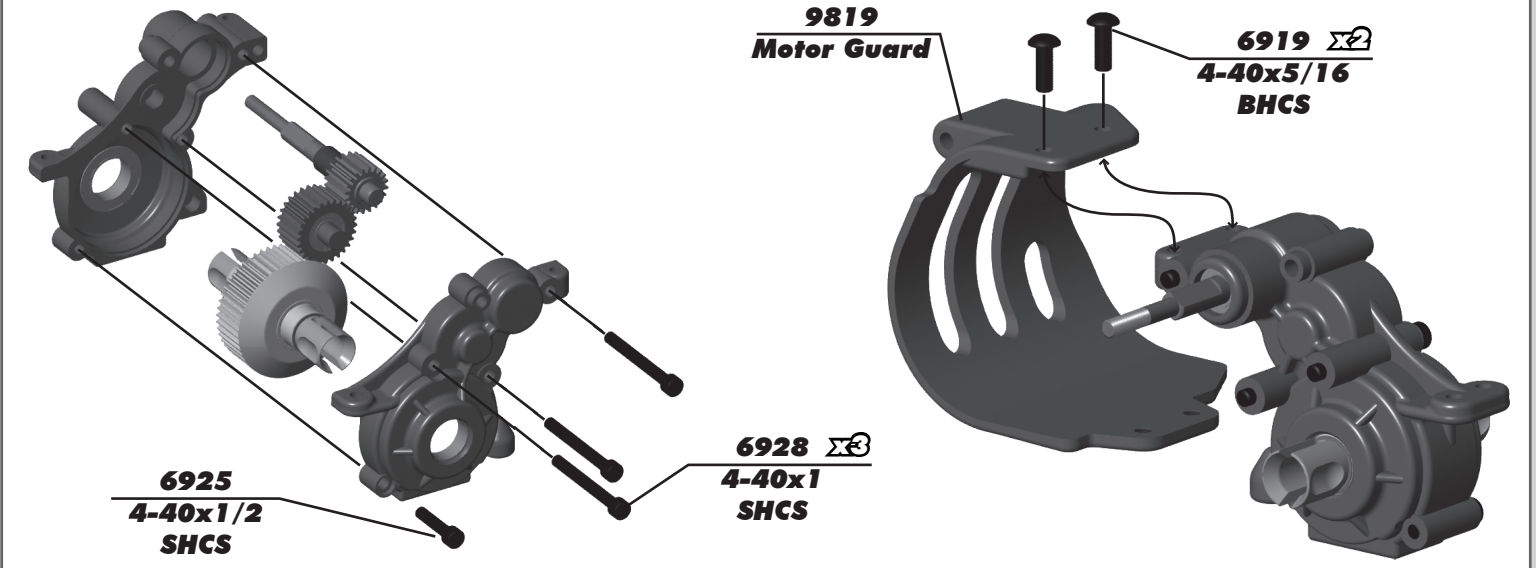

**:: Transmission Build - Bag C 8/9 - Step 7**

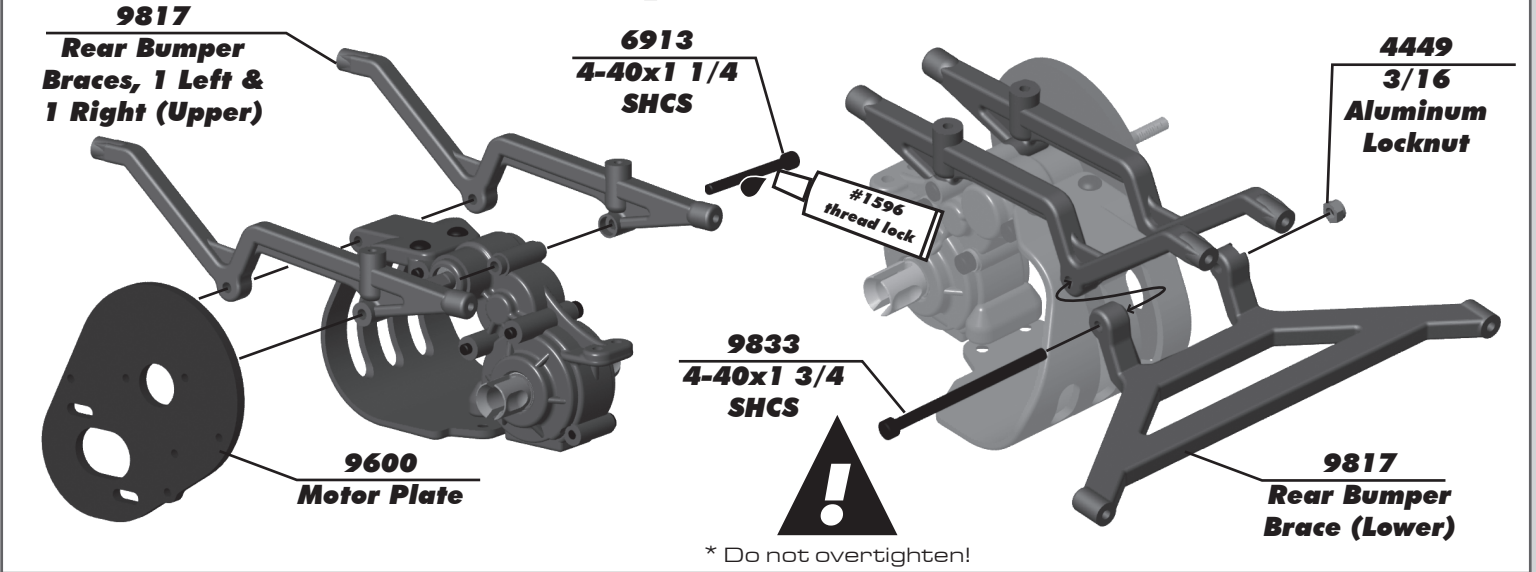

**:: Transmission Build - Bag C 10 - Step 8**

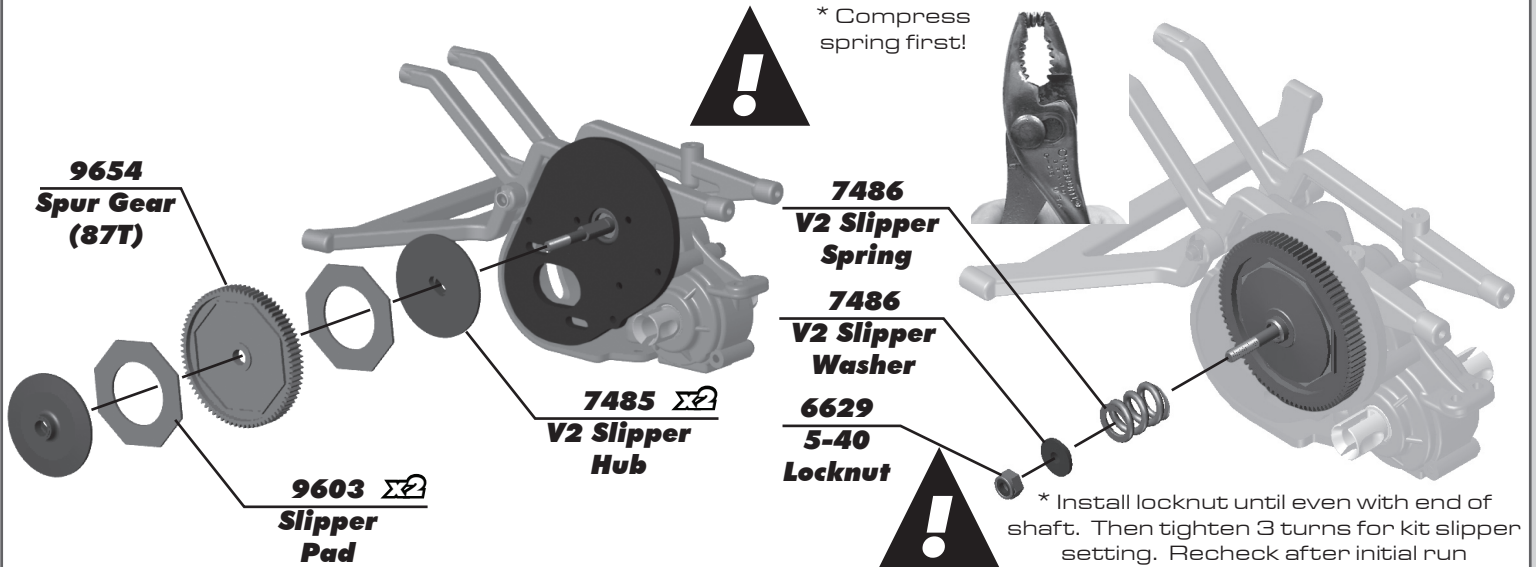

**:: Rear Arms Build - Bag D 2 - Step 1**

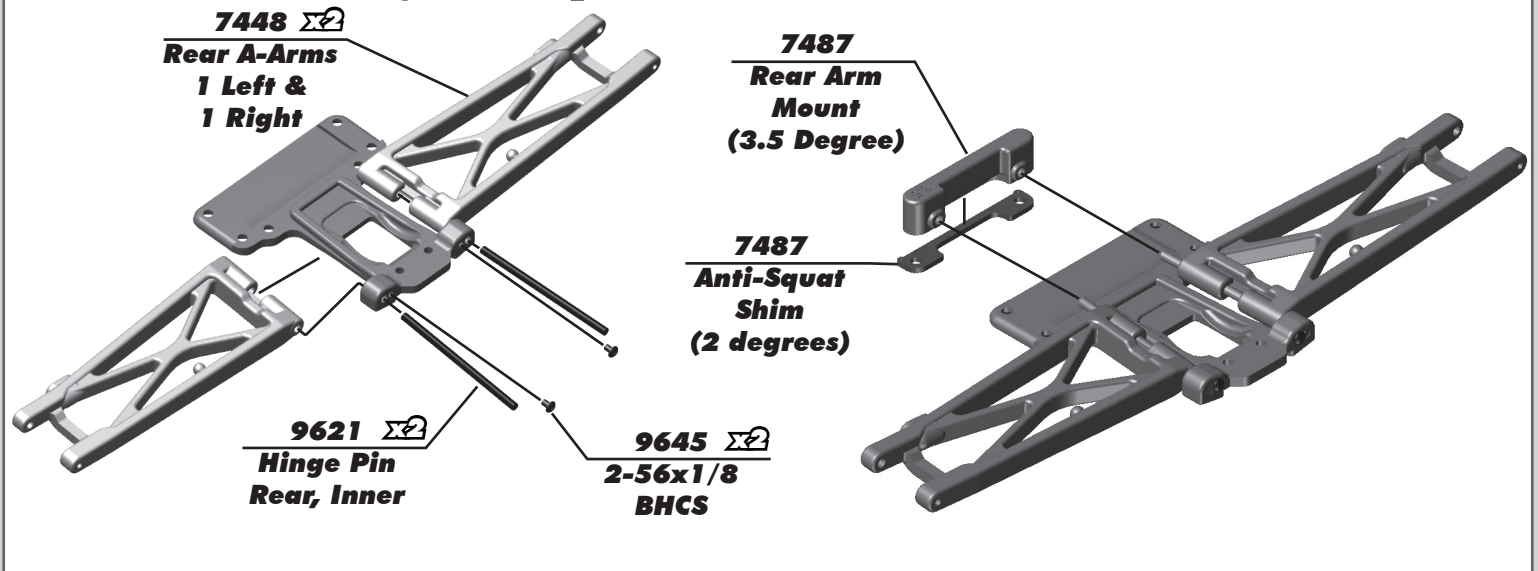

**:: Rear Arms Build - Bag D 2 - Step 2**

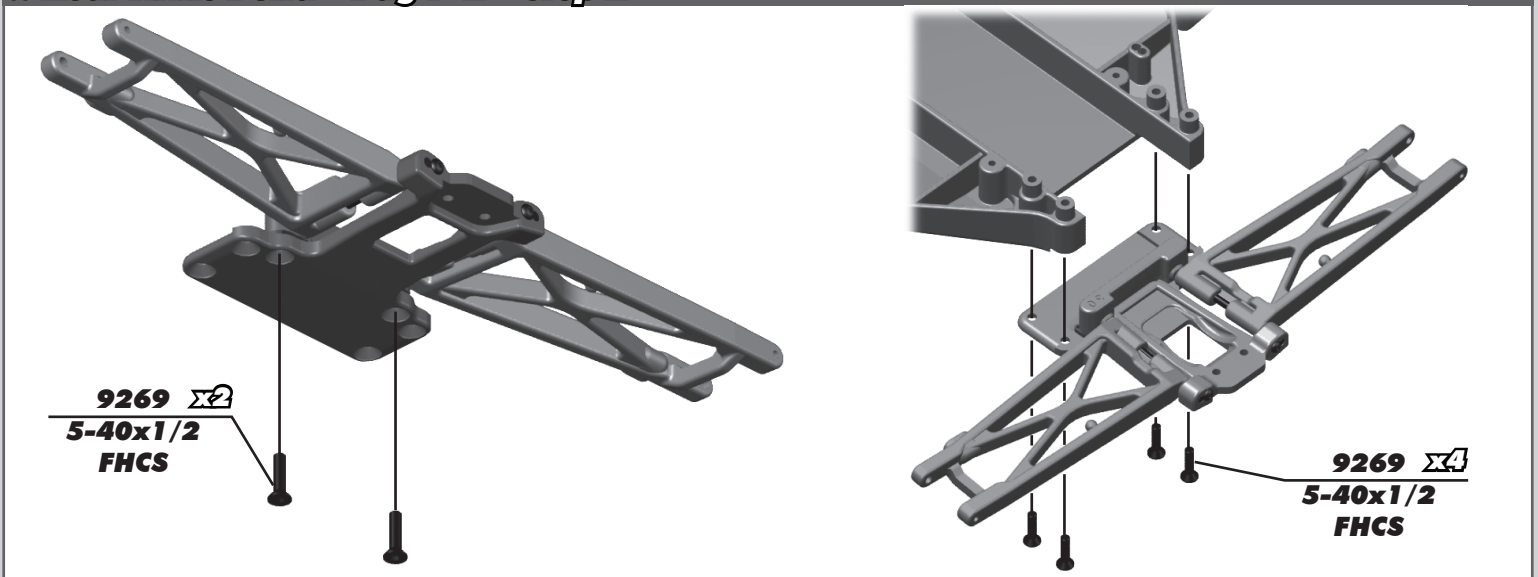

**:: Rear Brace Build - Bag D 3 - Step 3**

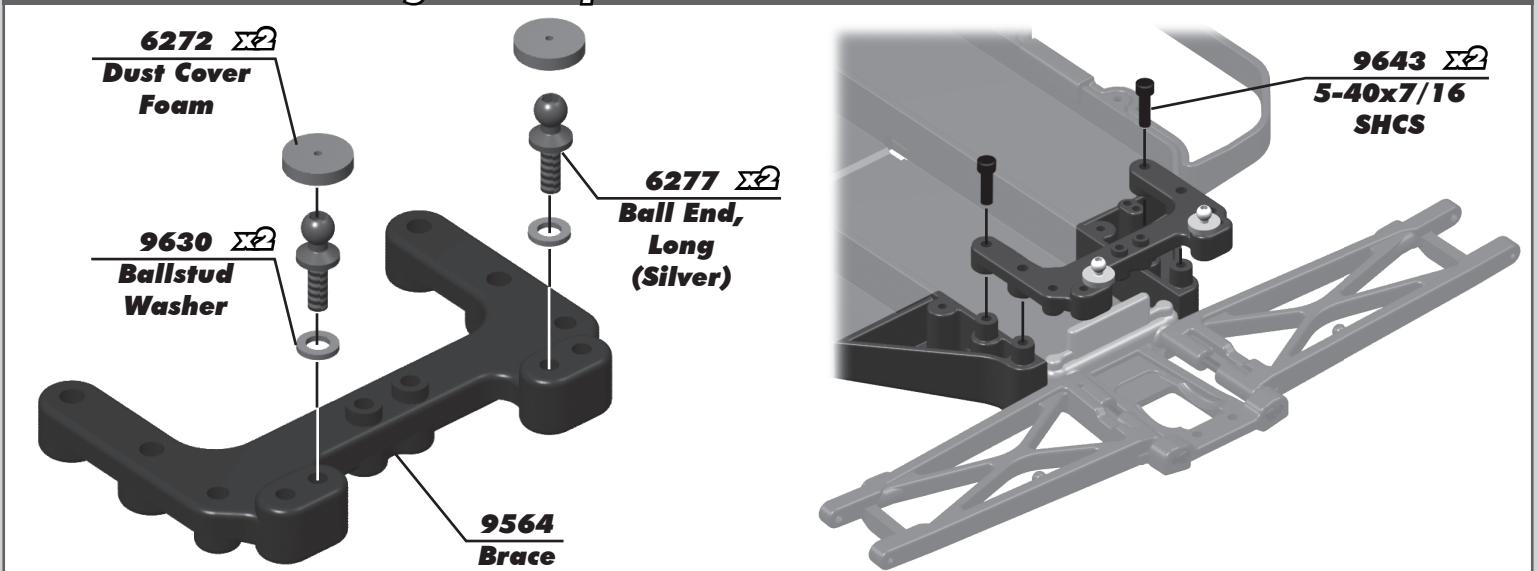

**:: Rear Shock Tower Build - Bag D 3 - Step 4**

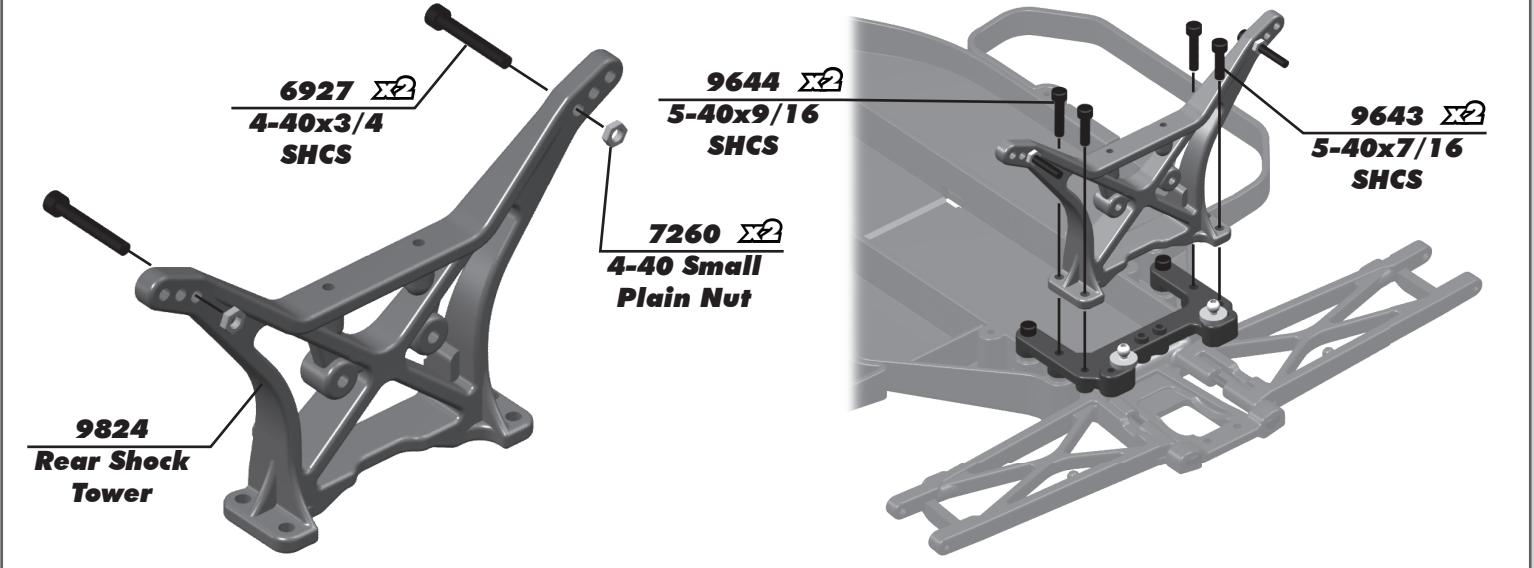

**:: Transmission Install - Bag D 4 - Step 5**

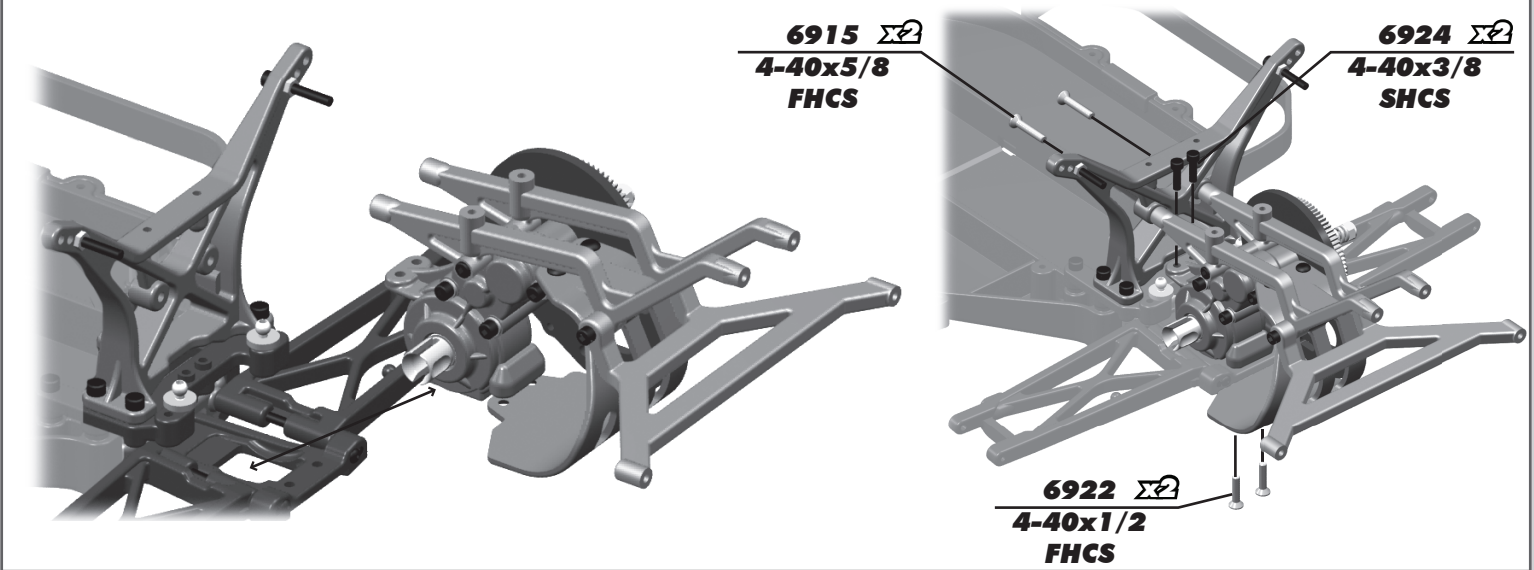

**:: Rear Upper Plate Build - Bag D 5 - Step 6**

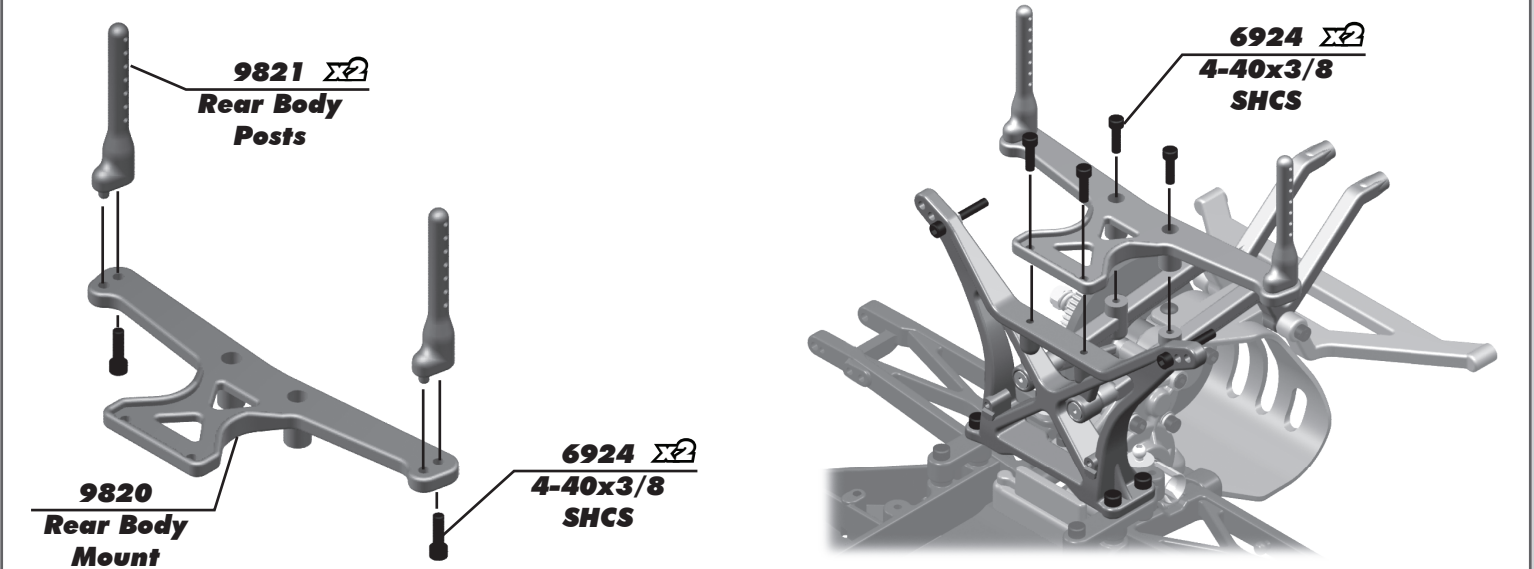

**:: Rear Bumper Build - Bag D 6 - Step 7**

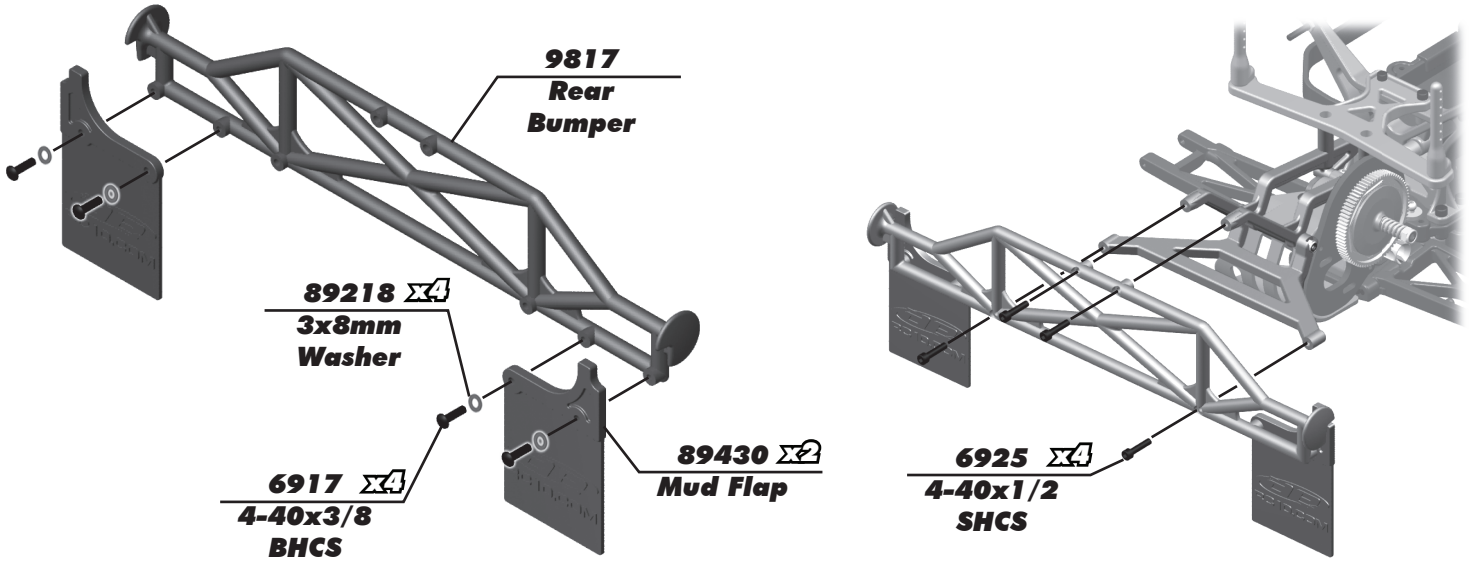

**:: Rear Hubs Build - Bag E 2 - Step 1**

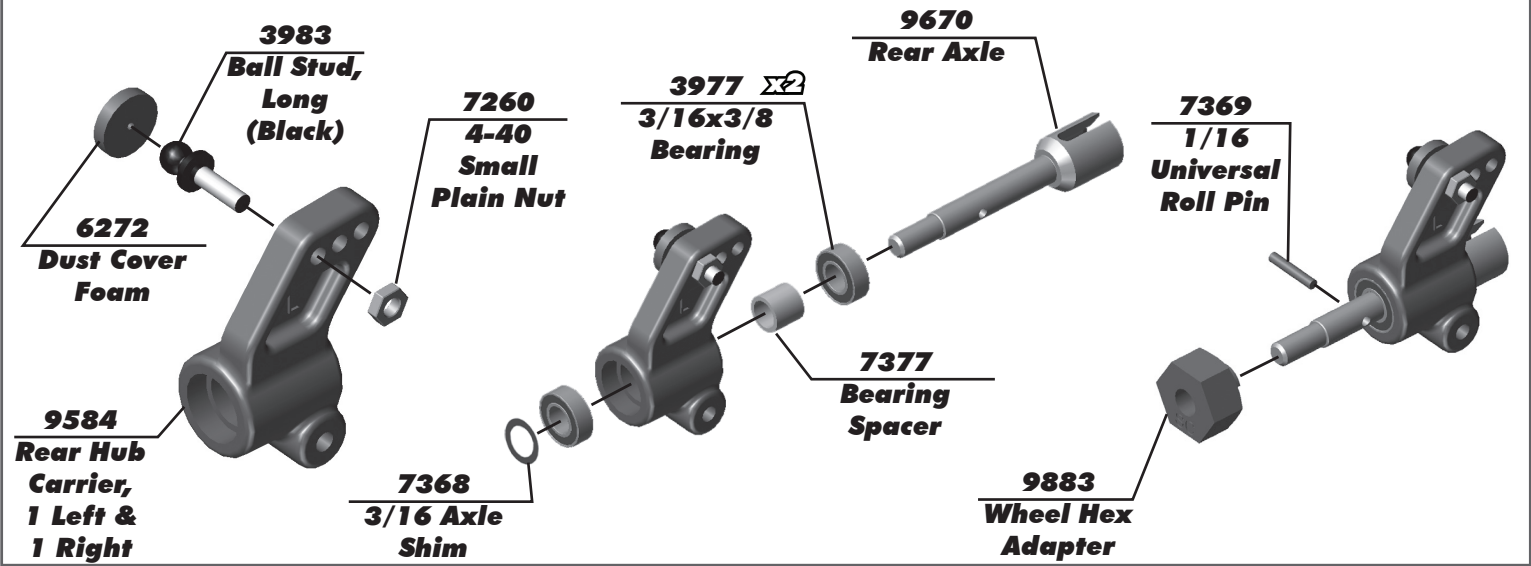

**:: Rear Hubs Build - Bag E 3/4/5 - Step 2**

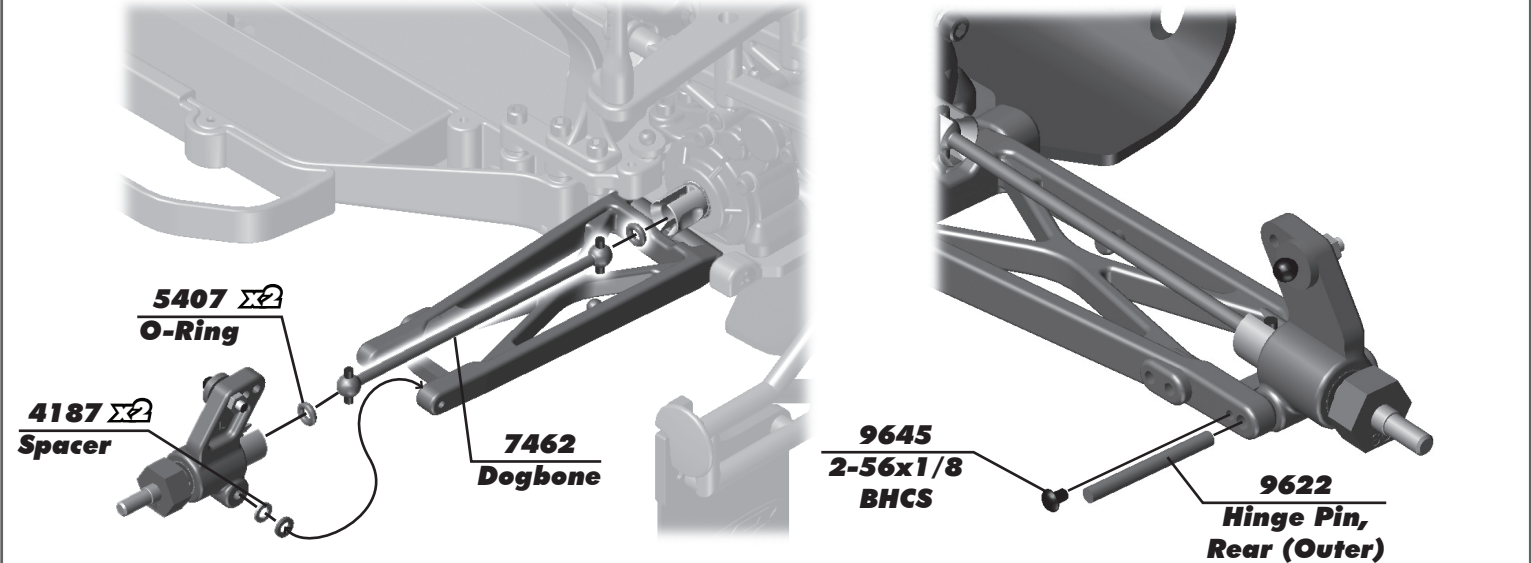

**:: Rear Hubs Build - Bag E 6 - Step 3**

\* Orient the notch to the left throughout the car. It indicates which end has the left hand threads.

**Build 2**  
3.59" (91.18mm)

**7101**  
2.80"  
Turnbuckle

**7230**  $\Sigma 2$   
Ball Cup,  
Large

**:: Shock Build - Bag F 2/3 - Step 1**

**9884**  
V2 RTR Front Shock Body, 1.02 Stroke (Blue)

**9885**  
V2 RTR Rear Shock Body, 1.39 Stroke (Blue)

**5407**  $\Sigma 2$   
O-Ring

**6469**  
Shock Cap O-Ring

**7484**  
Shock Internal Spacer

**7484**  
Lower Shock Seal Cap

**Remove Burrs**

**Piston Number Here!**  
Front Shocks Use #3  
Rear Shocks Use #1

**6465**  
Shock Piston

**6459**  
Front Shock Shaft 1.02 Stroke

**6458**  
Rear Shock Shaft 1.32 Stroke

**6299**  $\Sigma 2$   
E-Clip

**:: Shock Build - Bag F 3 - Step 2**

**6466**  $\Sigma 5$   
Downstop 1/32 (Front x5) (Rear x2)

**RACERS TIP!**  
Use Green Slime AE #1105 on the threads of the shock shaft before installation!

**7217**  
Eyelet

**7217**  
Pivot Ball

**:: Shock Build - Bag F 3 - Step 3**

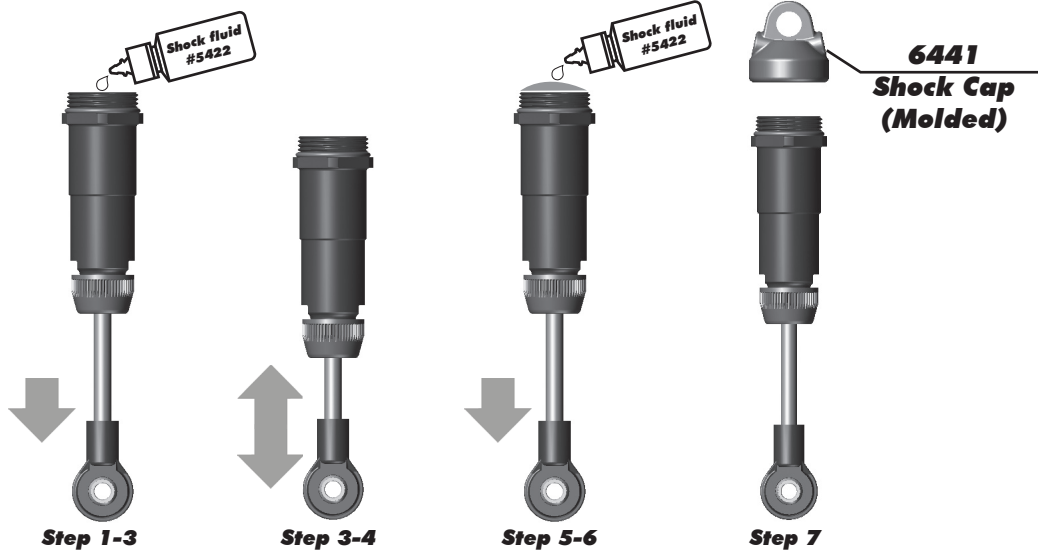

**Shock Bleeding Steps:**

1. Pull shock shaft down.
2. Fill shock body 3/4 full with silicone fluid.
3. Slowly move the shock shaft up and down to remove air from under piston. Wait for bubbles to come to surface.
4. Fill shock body to top with silicone fluid.
5. Place a drop of oil in the cap and on cap threads.
6. Install cap and tighten completely.
7. Slowly compress shaft all the way to the top. If there is pressure at the top of the stroke, there is too much oil or air. You must bleed it out.
8. Slowly pull shaft out.
9. Unscrew the cap 3/4 turn and tilt the shock at a slight angle.
10. Slowly compress the shaft to push out excess oil and air. You should see bubbles coming out from under the cap.
11. With the shaft compressed, tighten the cap and re-check for pressure at the top of the stroke. If there is still pressure, repeat steps 9 thru 11.

**:: Shock Build - Bag F 4/5 - Step 4**

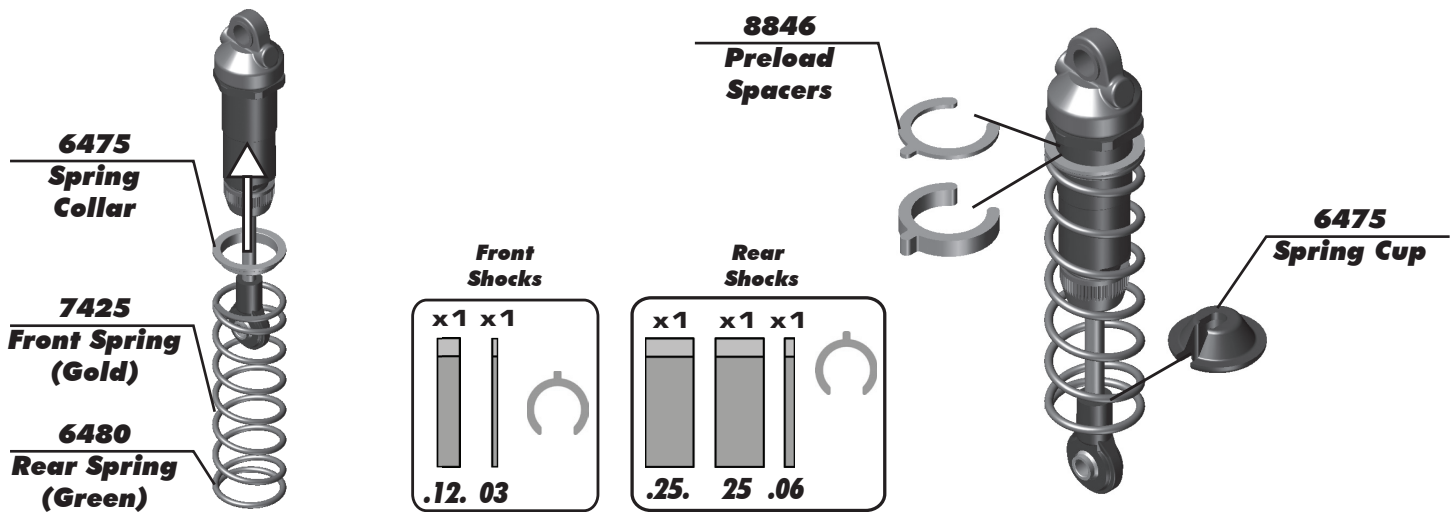

**:: Shock Build - Bag F 6 - Step 5**

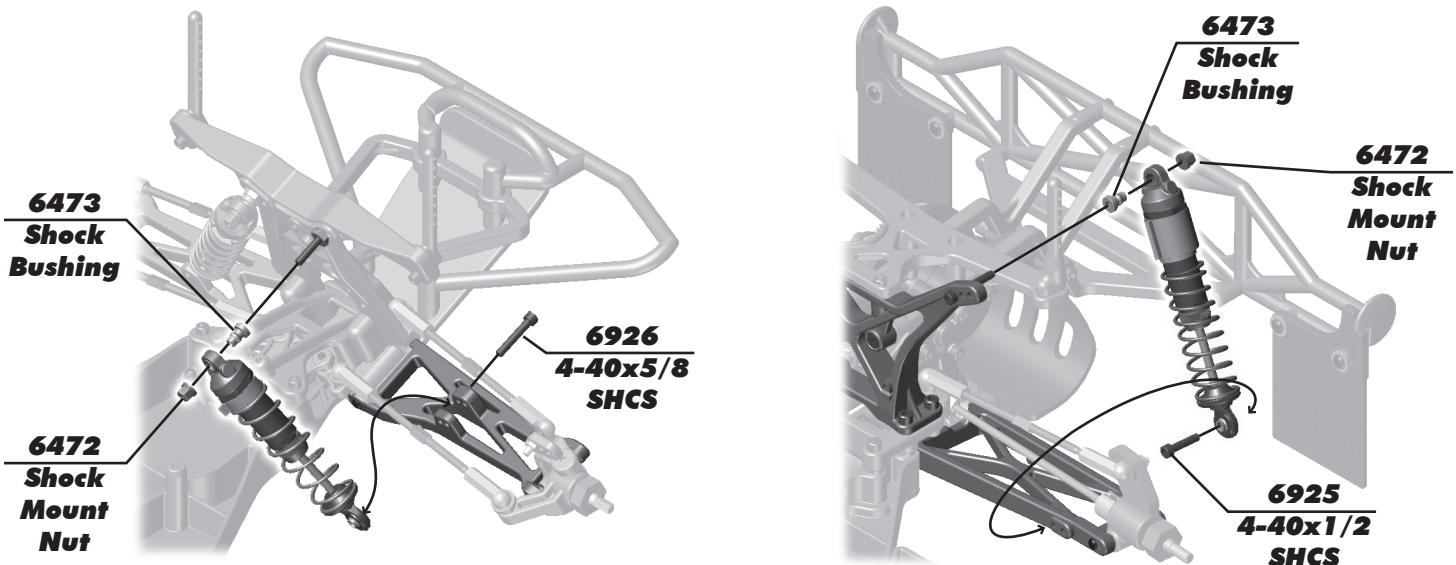



**:: Electronics Build - Bag G 2/3 - Step 1**

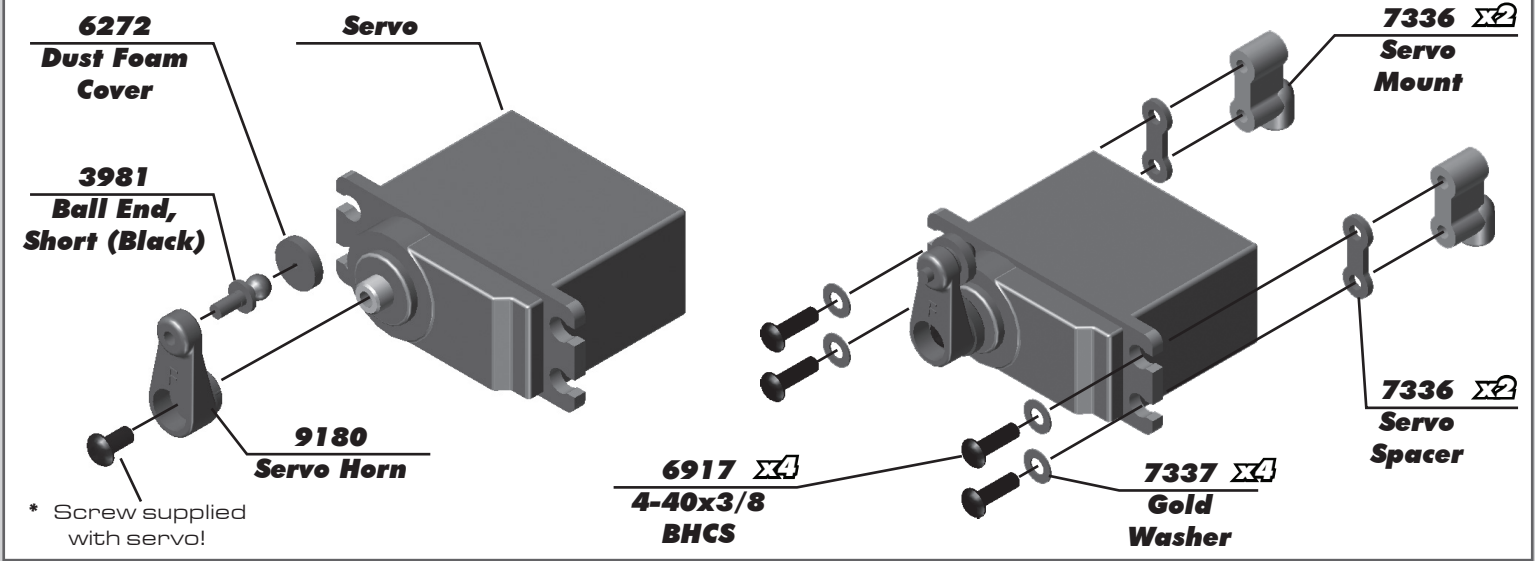

**:: Electronics Build - Bag G 4 - Step 2**

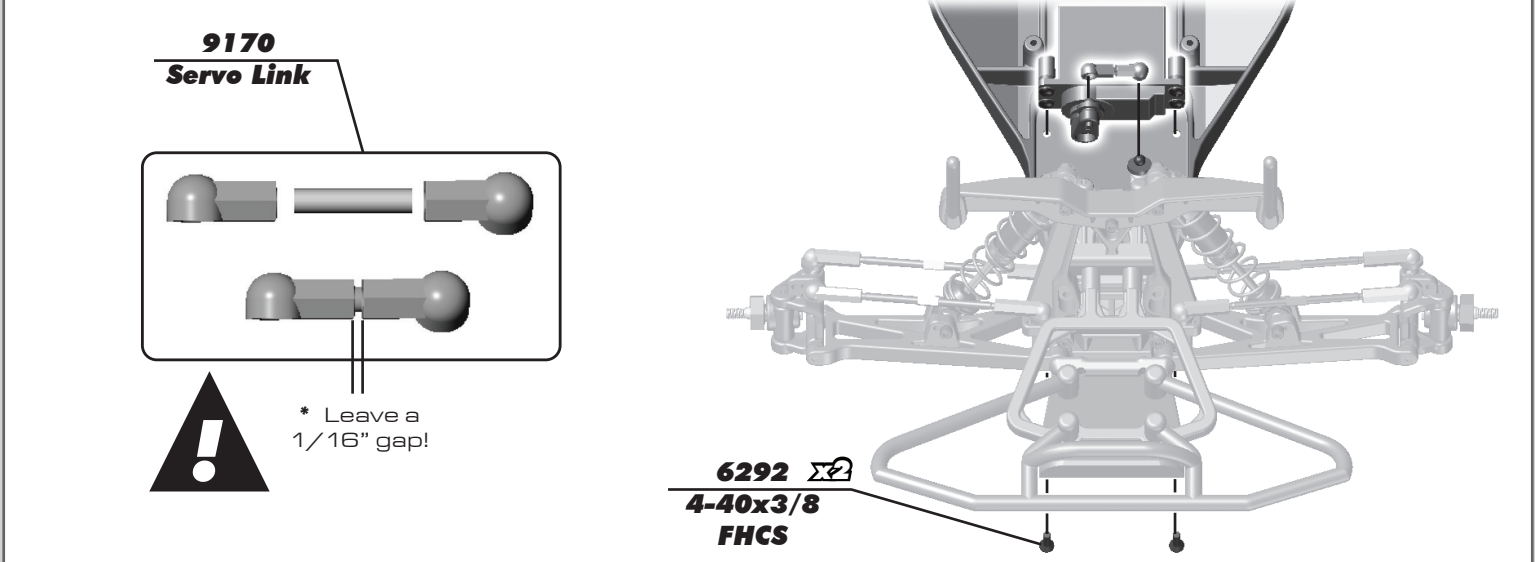

**:: Electronics Build - Bag G 5/6 - Step 3**

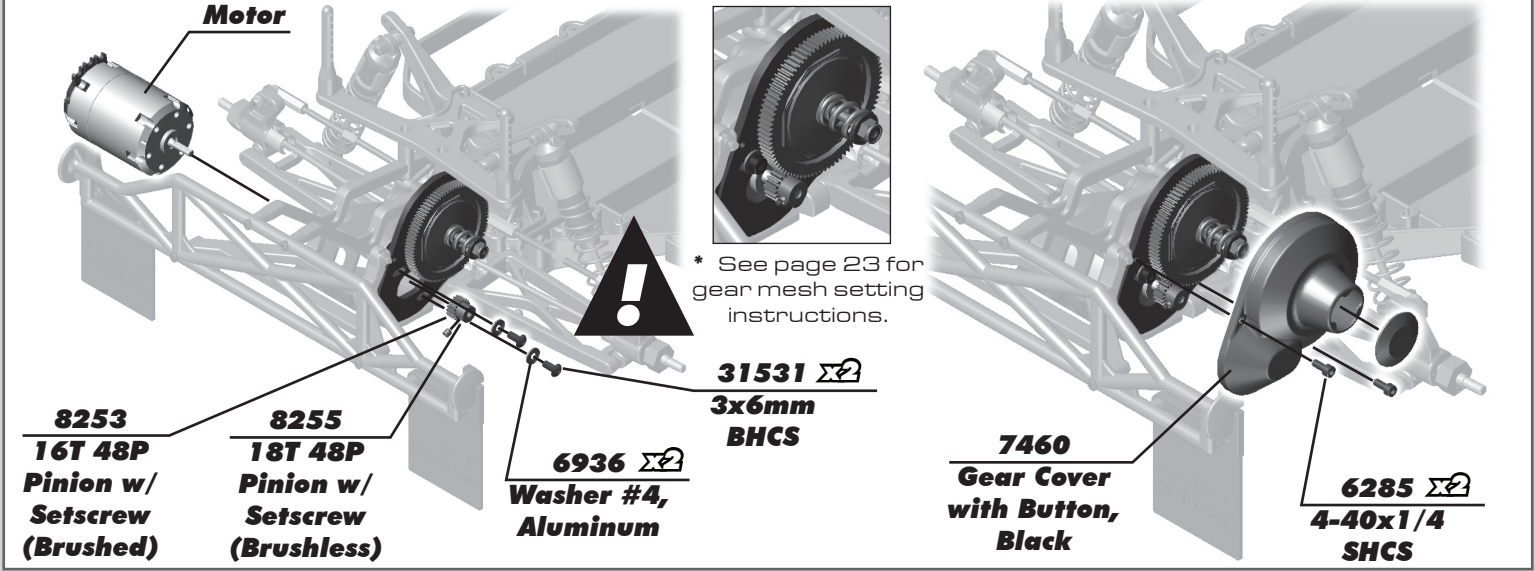

**:: Electronics Build - Bag G 7/8 - Step 4**

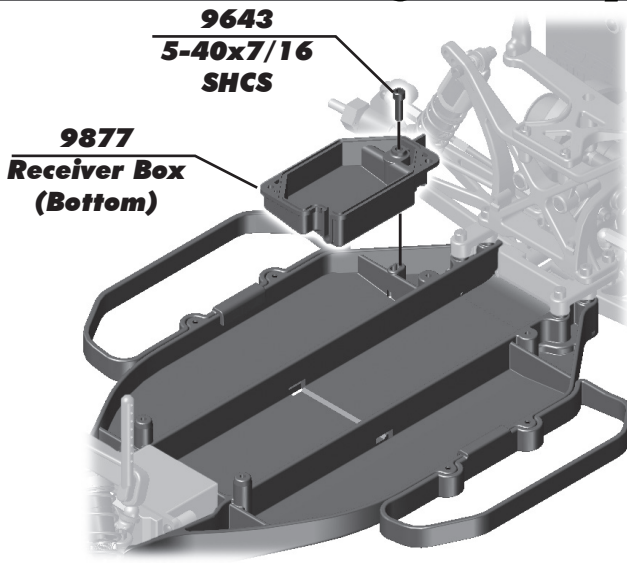

**Speed Control**



\* Install the ESC with servo tape.

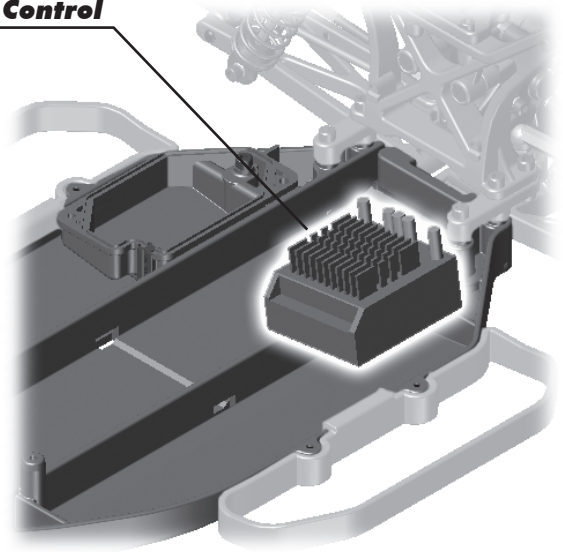

**:: Electronics Build - Bag G 7/8 - Step 5**

**9878 Receiver Box Grommet**

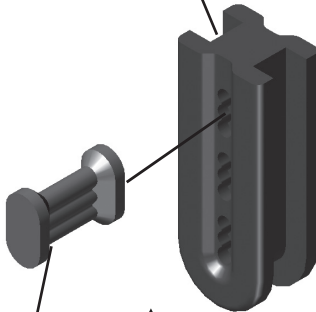

**9878 Wire Grommet Plug**



\* Receiver grommet plug can be removed if you use a personal transponder!



\* Install the ESC wires and the Servo wires into the wire grommet before installing the grommet into the receiver box!

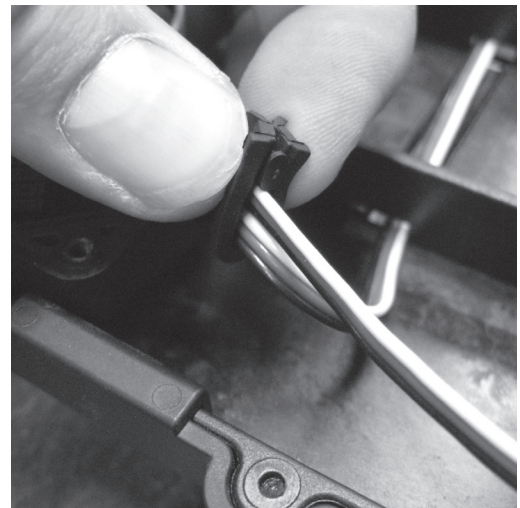

**:: Electronics Build - Bag G 7/8 - Step 6**

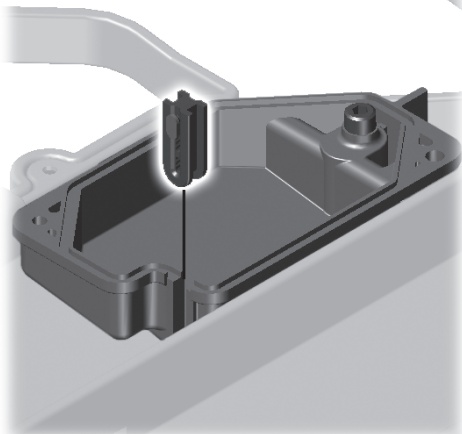

**Receiver**



\* You may need to reposition the receiver in order to get it to fit with the plugs installed and the receiver box lid installed. Once you find a good fit, use servo tape to install your receiver!

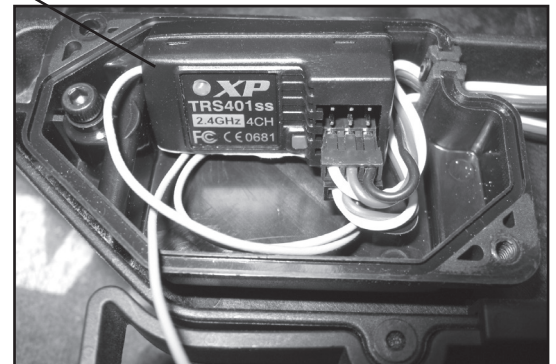

**:: Electronics Build - Bag G 7/8 - Step 7**

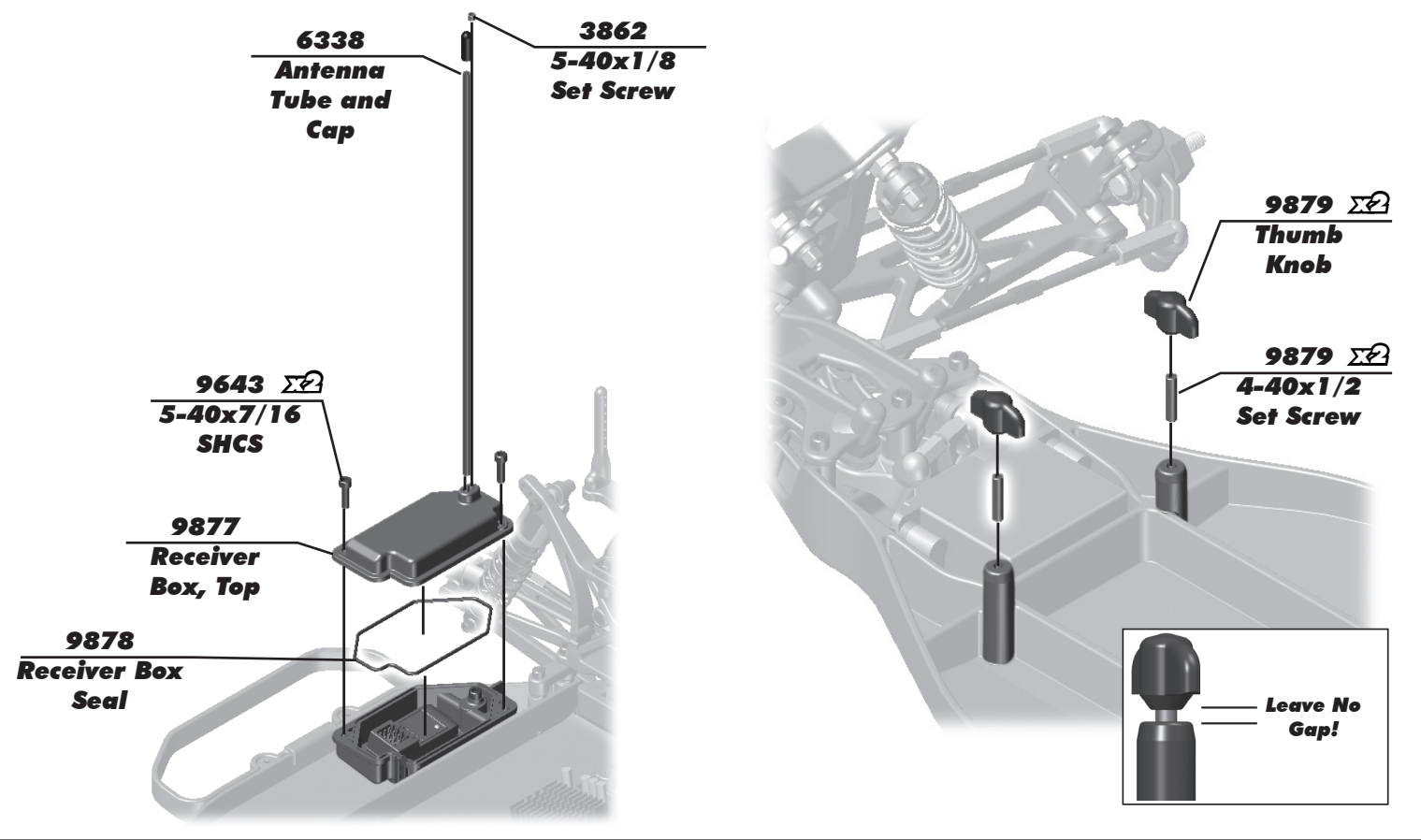

**:: Electronics Build - Bag G 7/8 - Step 8**



\* You can trim the foam to move the battery pack in order to adjust the balance of the vehicle!

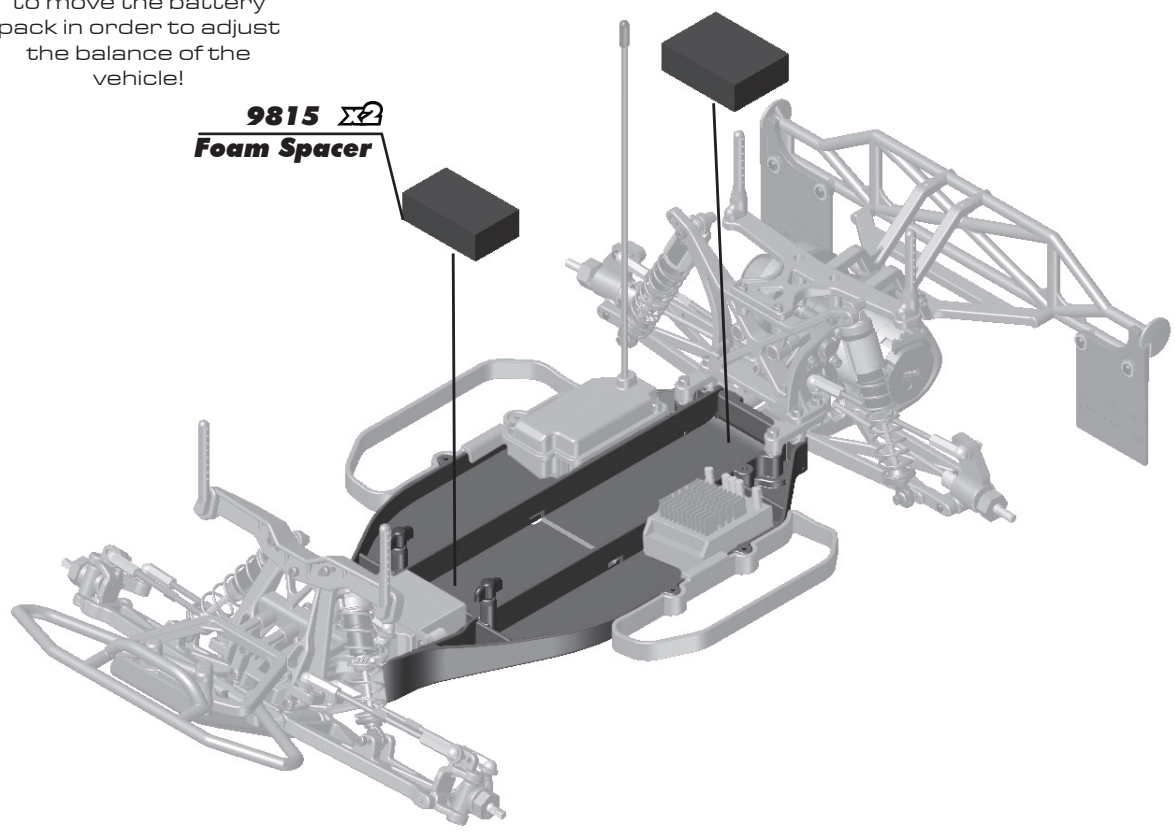

## :: Electronics Build - Bag G 7/8 - Step 9

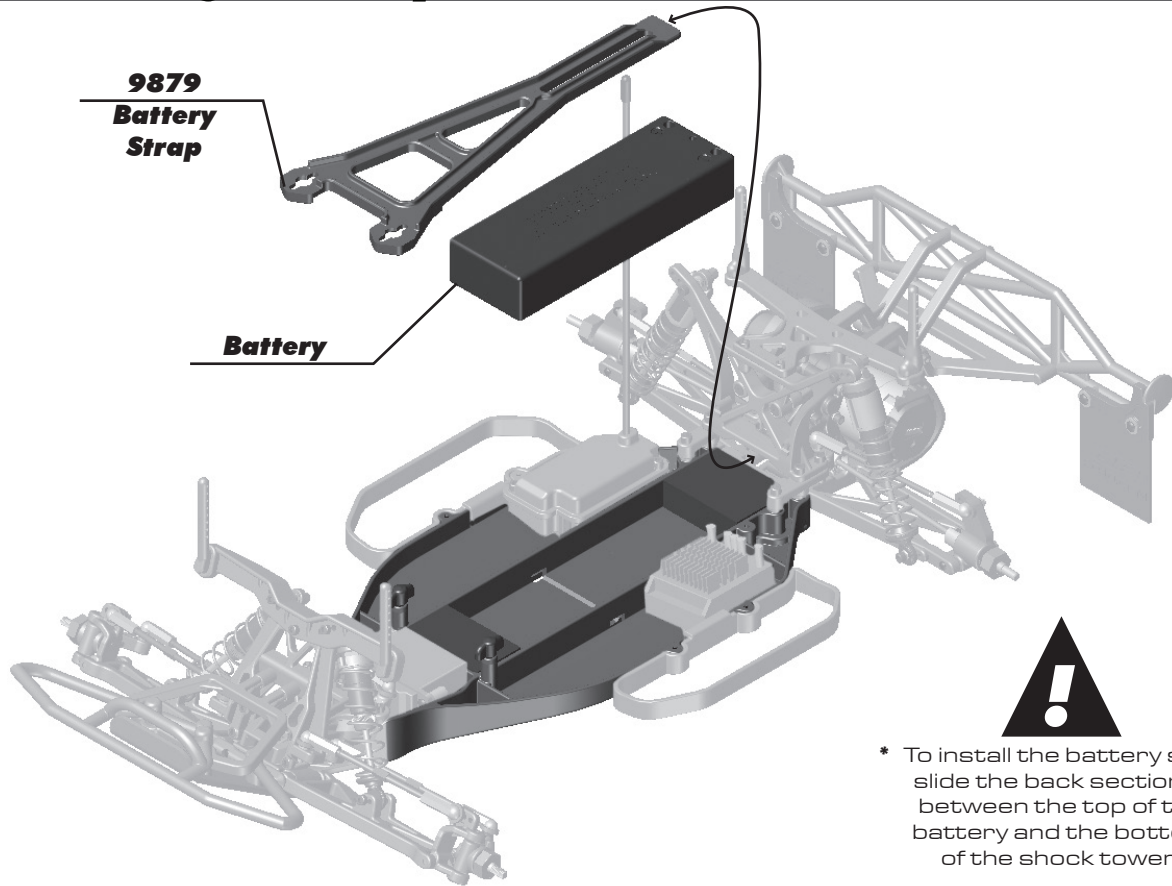

\* To install the battery strap, slide the back section in between the top of the battery and the bottom of the shock tower!

## :: Electronics Build - Bag G 7/8 - Step 10

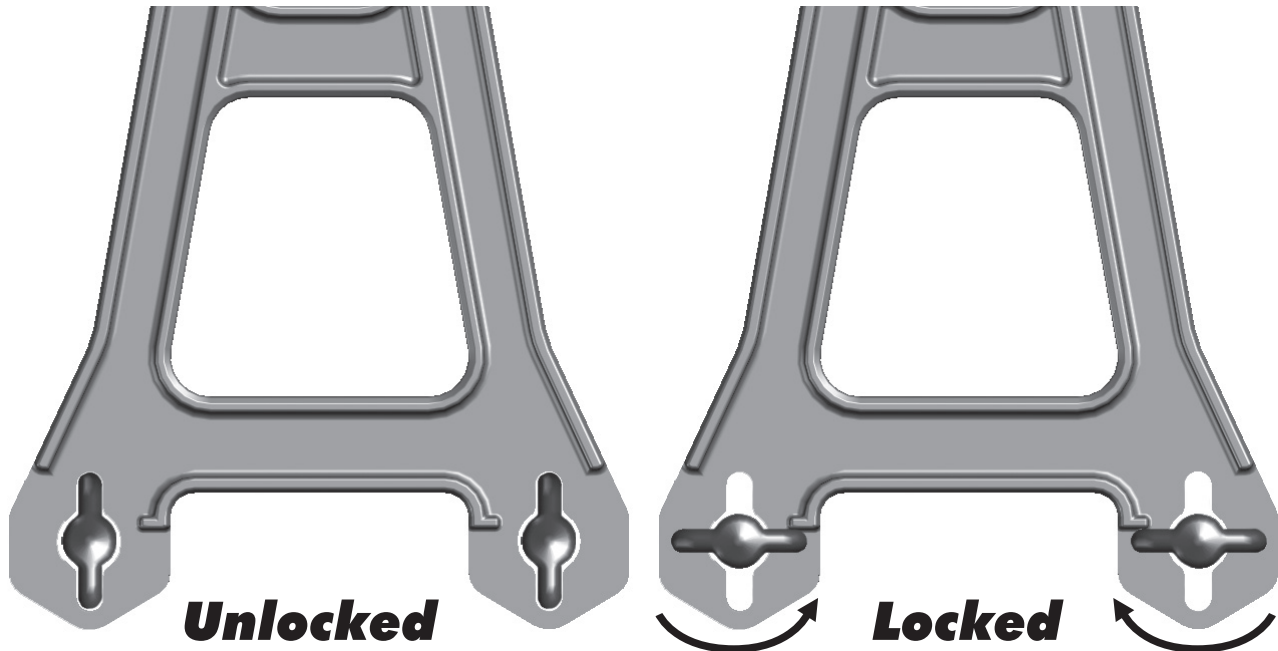

**To remove your battery pack from the vehicle, twist the thumb screws to the unlocked position, remove the battery strap, and then remove the battery.**

**When you install your battery pack, install the battery strap and make sure the thumb screws are locked before operation.**



**You may need to adjust the height of the thumb screws and/or the set screws that the thumb screws are attached to for your specific battery pack.**

**:: Wheels and Tires Build - Bag H 1 - Step 1**

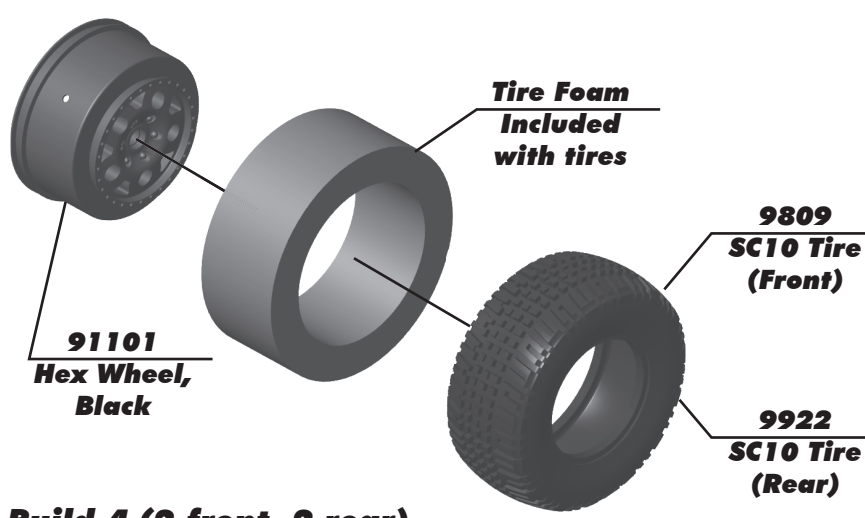

**Build 4 (2 front, 2 rear)**



Carefully apply ca glue (tire adhesive) to the tire bead on both sides. Do one side at a time, allow it to dry before gluing the other side!  
**CA glue not included!**

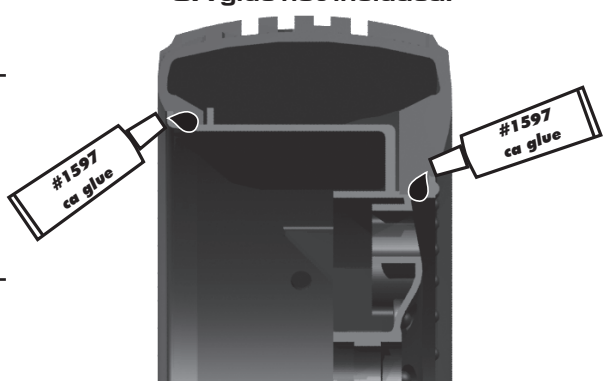

**:: Wheels and Tires Build - Bag H 2 - Step 2**

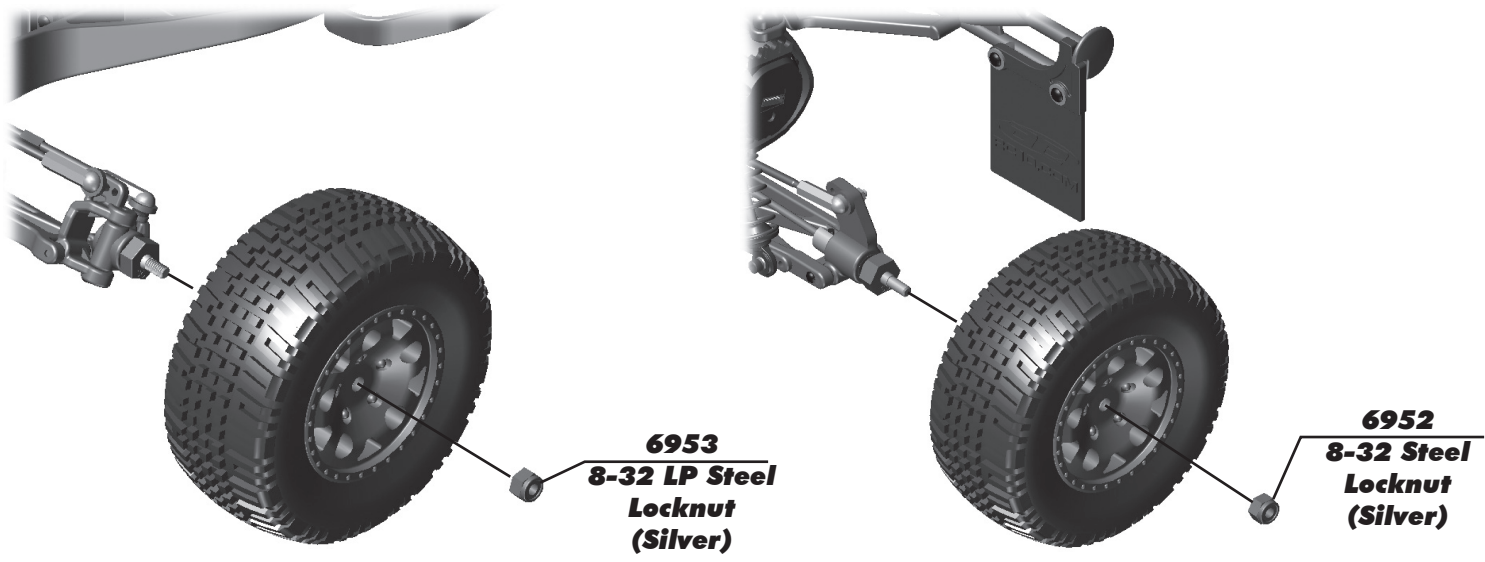

**:: Body Build - Bag H 2 - Step 3**

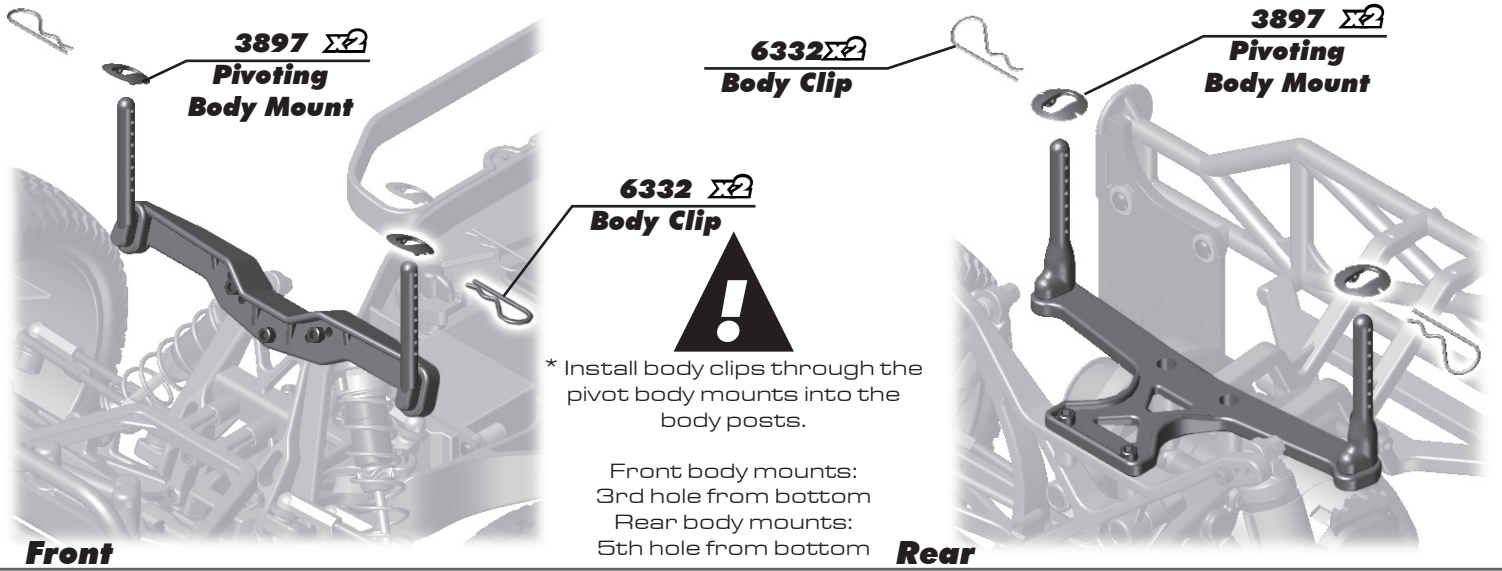

\* Install body clips through the pivot body mounts into the body posts.

Front body mounts:  
3rd hole from bottom  
Rear body mounts:  
5th hole from bottom

**Front**

**Rear**

**:: Wheels and Tires Build - Bag H 2 - Step 4**

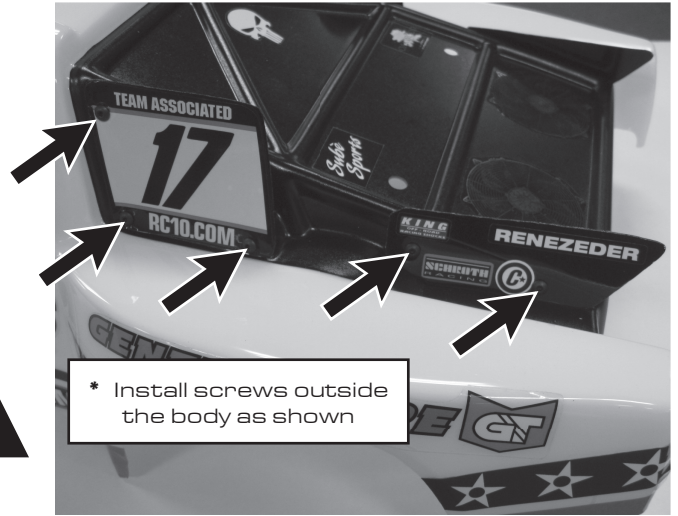
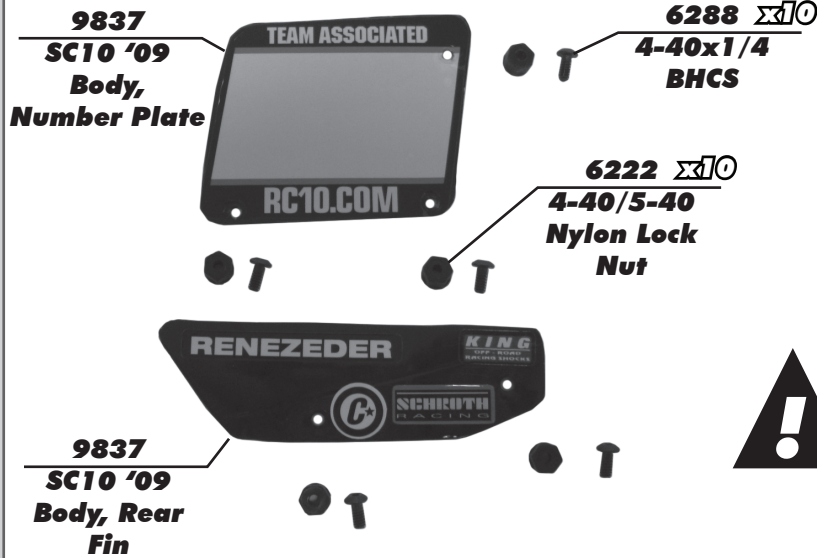

**:: Wheels and Tires Build - Bag H 2 - Step 5**

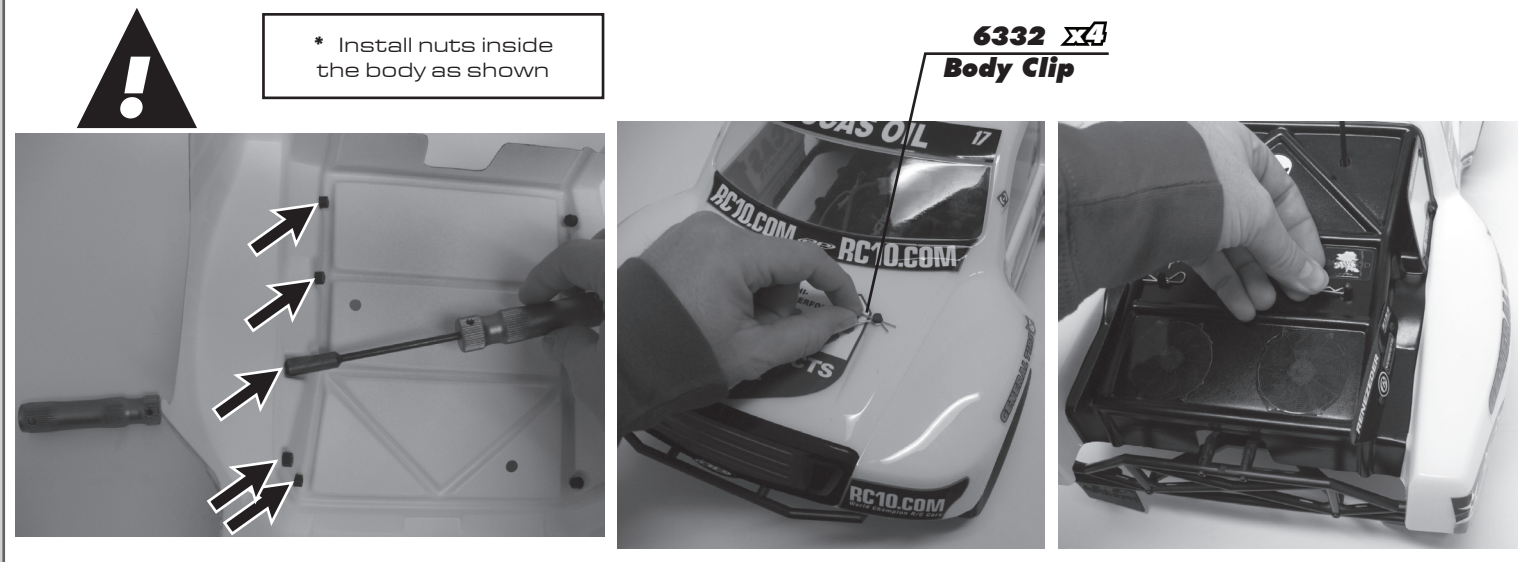

**:: FINAL ADJUSTMENTS**

Use the following steps to make the final adjustments on your truck.

1. Turn the transmitter on.
2. Connect your battery pack and turn the power switch on.
3. Move the steering control on the transmitter to the right and left. Do the wheels move in the correct direction? If not, you must reverse the steering servo direction on your transmitter (see transmitter manual).
4. Adjust your steering trim (see radio manual) until the steering rack is centered under the top plate. Then, using the two steering turnbuckles, adjust the front wheels so they are pointing straight ahead.
5. Adjust the ESC (electronic speed control) according to the speed control manufacturer's instructions (your SC10 RTR ESC should be set right out of the box). Now turn the power switch off.
6. Place your car on a block or car stand so that all four wheels are elevated. Turn the power switch on again. Check the throttle, brake, and steering settings you have made and then turn the power switch back off.
7. Remember! The transmitter is always the **FIRST TO BE TURNED ON** and **THE LAST TO BE TURNED OFF**.

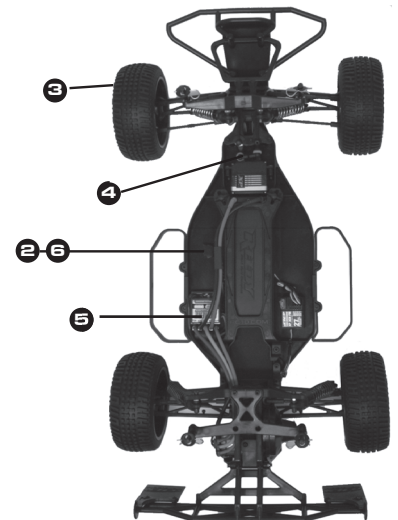

## :: Tuning Tips

### Tips for Beginners:

Before making any changes to the standard setup, make sure you can get around the track without crashing. Changes to your vehicle will not be beneficial if you can't stay on the track. Your goal is consistent laps.

Once you can get around the track consistently, start tuning your vehicle. Make only ONE adjustment at a time, testing it before making another change. If the result of your adjustment is a faster lap, mark the change on the included setup sheet (make additional copies of the sheet before writing on it). If your adjustment results in a slower lap, revert back to the previous setup and try another change.

When you are satisfied with your vehicle, fill in the setup sheet thoroughly and file it away. Use this as a guide for future track days or conditions. Periodically check all moving suspension parts. Suspension components must be kept clean and move freely without binding to prevent poor and/or inconsistent handling.

### Motor Gearing:

Proper motor gearing will result in maximum performance and run time while reducing the chance of overheating and premature motor failure. The gear ratio chart lists recommended **starting gear ratios** for the most widely used motor types. Gear ratios will vary depending upon motor brand, wind, and electronic speed control. Consult your motor and electronic speed control manufacturers for more information.

Team Associated is not responsible for motor damage due to improper gearing.

#### SC10 Gear Ratio Chart (Internal Gear Ratio 2.60:1)

Motor	Pinion	Spur	Final Drive Ratio
Radon Motor	16	87	14.13:1
17.5 Reedy Sonic Brushless	*28	*75	6.96:1
13.5 Reedy Sonic Brushless	*26	*75	7.50:1
10.5 Reedy Sonic Brushless	*24	87	9.42:1
3300kV Brushless	18	87	12.57:1

\* **Optional spur gear / pinion used**

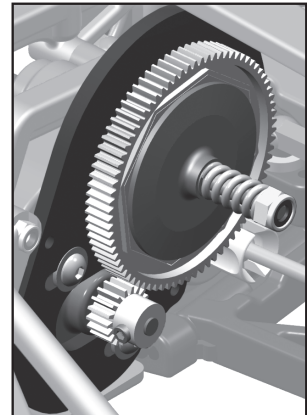

### Set The Gear Mesh:

You should be able to rock the spur gear back and forth in the teeth of the pinion gear without making the pinion gear move. If the spur gear mesh is tight, then loosen the #31531 screws and move the motor away, then try again. A gear mesh that is too tight or too loose will reduce power and damage the gear teeth.

### Motor Maintenance:

**Brushed motors require frequent maintenance to keep performance levels at their maximum.**

Periodically, remove the brushes from their holders and inspect the tips for wear or burning. If there is noticeable wear (less than 75% of the brush remaining), replace the brush with a new pair. If the tips become a burned blue color, the lubricant in the brush has been burned away and new brushes should be installed.

Occasionally, the motor should be cleaned with a soft brush to prevent dirt build up around the brush hood area and ball bearings. At this time, it is a good idea to add one drop of bushing / bearing oil to each bushing or ball bearing.

If using a brushless motor, please refer to the motor manufacturer's guidelines for proper maintenance.

### Slipper Clutch:

The assembly instructions give you a base setting for your clutch. Turn the nut on the shaft so that the end of the top shaft is even with the outside of the nut, then tighten with three more turns. At the track, tighten or loosen the nut in 1/8 turn increments until you hear a faint slipping sound for 1-2 feet on takeoffs. Another popular way to set the clutch is to hold both rear tires firmly in place and apply short bursts of throttle. If the clutch is properly set, the front tires should lift slightly up off the surface.

## :: Tuning Tips (cont.)

### Wheelbase Adjustment:

You have three options for rear hub spacing, Forward, Middle, & Back. The kit setting provides the most rear traction, and will be used most often. A short wheelbase will make the rear end more responsive

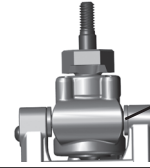

\*Spacers to the rear will place hubs forward, shortening the wheelbase



### Front Camber:

Camber describes the angle at which the tire and wheel rides when looked at from the front. Negative camber means that the tire leans inward at the top. A good starting camber setting is  $-1^\circ$ . Positive camber, where the top of the tire is leaning out, is not recommended. # 1719 camber gauge can be used to more accurately set camber.

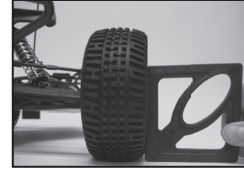

\*Testing camber with camber gauge



### Rear Camber:

Camber describes the angle at which the tire and wheel rides when looked at from the back. Negative camber means that the tire leans inward at the top. A good starting camber setting is  $-1^\circ$ . Adding a small amount of positive camber, where the top of the tire is leaning out, will tend to improve straight-line acceleration on loose tracks. # 1719 camber gauge can be used to more accurately set camber.

### Front Camber Links:

Changing the length of the camber link is considered a bigger step than adjusting the ball end height on the tower. Shortening the camber link (or lowering the ball end) will give the front end less roll and quicken steering response. Lengthening the camber link (or raising the ball end) will give the front more roll and slower steering response. Longer camber links are typically used on high grip tracks and shorter links tend to work better on medium-grip loose tracks.



\*Raise or lower the ball end by adding or subtracting washers here



### Rear Camber Link:

Changing the length of the camber link is considered a bigger step than adjusting the ball end height on the rear chassis brace. Shortening the camber link (or lowering the ball end) will give the rear end less roll and the car will tend to accelerate or "square up" better. Lengthening the camber link (or raising the ball end) will give the rear more roll and more cornering grip. Longer camber links are typically used on high grip tracks, while shorter links tend to work better on medium grip loose tracks. The kit setting is the best compromise of cornering grip and acceleration.

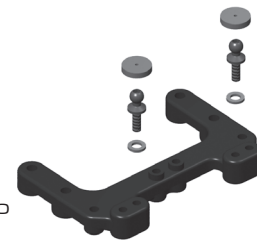

\*Raise or lower the ball end by adding or subtracting washers here



### Ride Height:

Ride height is the distance from the ground to the bottom of the chassis. The standard front ride height setting is with the front arms level (referred to as "arms level"). Check the ride height by lifting up the entire car about 8-12 inches off the bench and drop it. After the suspension "settles" into place, add or remove pre-load clips so that the left & right arms appear to be level.

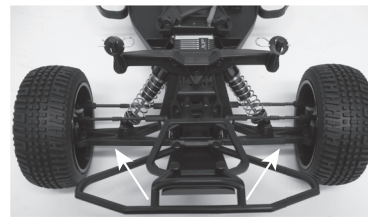

\*Front arms should be in a straight line when ride height is set at "arms level"



The rear ride height setting you should use most often is with the outdrive, driveshaft, and axles all on the same imaginary horizontal line (referred to as "bones level"). Check the ride height by lifting up the entire car about 8-12 inches off the bench and drop it. After the suspension "settles" into place, add or remove pre-load clips so that the left & right driveshafts appear to be level.

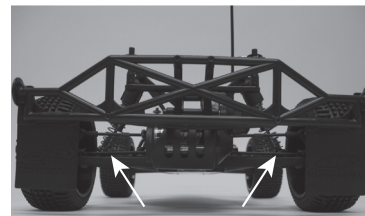

\*Dogbones should be in a straight line when ride height is set at "dogbones level"



### Caster:

Caster describes the angle of the kingpin as it leans toward the rear of the vehicle. Positive caster means the kingpin leans rearward at the top.



**:: Shocks**

5407	Red O-Rings	8
6299	1/8" E-Clips	12
6441	Shock Cap, Molded	4
6458	Shock Shaft, 1.32" stroke	1
6459	Shock Shaft, 1.02" stroke	1
6465	Shock Pistons, 4 each of #1,2, & 3	1
6466	Shock Down Stops, Set	1
6469	Black Shock Cap O-Ring	4
6472	Shock Mount Nut	4
6473	Shock Bushings	4
6475	Preload Spacers, Collars & Cups 4 thicknesses, 4 sets each	1
6925	4-40 x 1/2" SHCS	6
6926	4-40 x 5/8" SHCS	6
7217	Shock Rod Ends / Plastic Pivot Balls	2
7484	V2 1/10 Shocks Rebuild Kit (rebuilds 4)	1
8846	Preload Spacers, 4 each of 4 different sizes	1
9884	V2 RTR Front Shock Bodies 1.02"	Pr.
9885	V2 RTR Rear Shock Bodies 1.39"	Pr.

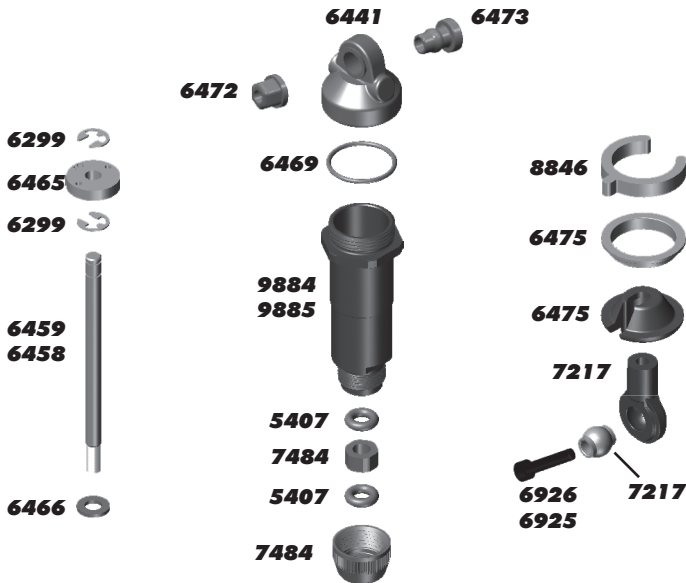

**:: Gear Differential**

9827	Complete Gear Diff	1
9828	Diff Gear and Cover	1
9829	Gear Diff Rebuild	1
9830	Gear Diff Outdrives, Set	1
9831	Gear Diff O-Ring Set	1
9832	10x16mm Bearing	2
9888	0.5mm Gear Diff Shim	2

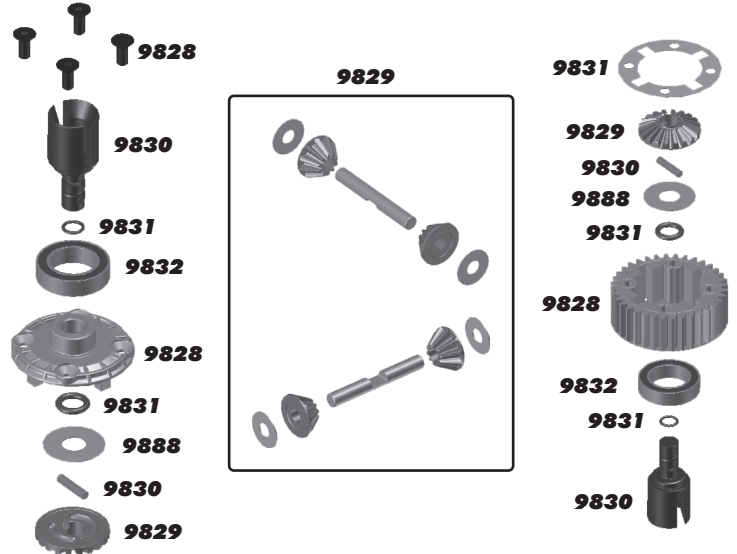

**:: Differential Fluids**

5450	Silicone Diff Fluid 1,000CST	1
5451	Silicone Diff Fluid 2,000CST	1
5452	Silicone Diff Fluid 3,000CST	1
5444	Silicone Diff Fluid 4,000CST	1
5453	Silicone Diff Fluid 5,000CST	1
5446	Silicone Diff Fluid 6,000CST	1
5454	Silicone Diff Fluid 7,000CST	1
5455	Silicone Diff Fluid 10,000CST	1
5466	Silicone Diff Fluid 15,000CST	1
5456	Silicone Diff Fluid 20,000CST	1
5457	Silicone Diff Fluid 30,000CST	1
5458	Silicone Diff Fluid 60,000CST	1
5448	Silicone Diff Fluid 80,000CST	1
5459	Silicone Diff Fluid 100,000CST	1
5461	Silicone Diff Fluid 200,000CST	1



**:: Shock Springs**

1580	Factory Team Truck Front Spring Kit. 1 pair green, silver, blue, gold, red front springs	1
1582	Factory Team Truck Front Spring Kit. 1 pair green, silver, blue, gold, red rear springs	1
6478	Rear Spring Silver 2.10 lb	Pr.
6480	Rear Spring Green 1.90 lb (Kit)	Pr.
6481	Rear Spring Black 1.74 lb	Pr.
6482	Rear Spring Gray 2.33 lb	Pr.
7425	Front Spring Gold 3.70 lb (Kit)	Pr.
7426	Front Spring Black 2.765 lb	Pr.
7427	Front Spring Green 2.99 lb	Pr.
7428	Front Spring Silver 3.225 lb	Pr.
7429	Front Spring Blue 3.45 lb	Pr.
7430	Front Spring Red 3.90 lb	Pr.
7434	Rear Spring Blue 2.55 lb	Pr.
7435	Rear Spring Gold 2.75 lb	Pr.
7436	Rear Spring Red 2.95 lb	Pr.



**:: Shock Fluid**

5420	10 Weight Silicone Shock Fluid	2oz.
5421	20 Weight Silicone Shock Fluid	2oz.
5422	30 Weight Silicone Shock Fluid	2oz.
5423	40 Weight Silicone Shock Fluid	2oz.
5424	22.5 Weight Silicone Shock Fluid	2oz.
5425	80 Weight Silicone Shock Fluid	2oz.
5426	27.5 Weight Silicone Shock Fluid	2oz.
5427	15 Weight Silicone Shock Fluid	2oz.
5428	25 Weight Silicone Shock Fluid	2oz.
5429	35 Weight Silicone Shock Fluid	2oz.
5430	45 Weight Silicone Shock Fluid	2oz.
5431	55 Weight Silicone Shock Fluid	2oz.
5432	32.5 Weight Silicone Shock Fluid	2oz.
5433	37.5 Weight Silicone Shock Fluid	2oz.
5434	42.5 Weight Silicone Shock Fluid	2oz.
5435	50 Weight Silicone Shock Fluid	2oz.
5436	60 Weight Silicone Shock Fluid	2oz.
5437	70 Weight Silicone Shock Fluid	2oz.
5438	47.5 Weight Silicone Shock Fluid	2oz.



**:: Transmission**

3977	Ball Bearing, 3/16" x 3/8"	2
6913	4-40 x 1 1/4" SHCS	6
6925	4-40 x 1/2" SHCS	6
6928	4-40 x 1" SHCS	6
9360	Idler Gear, molded	1
9361	Idler Gear Shaft	1
9600	B4/T4 Motor Plate	1
9601	B4/T4 Top Shaft	1
9602	B4/T4 Top Shaft Spacer	1
9826	SC10 Transmission Case (left & right)	1
9832	Ball Bearing, 10 x 16mm	2

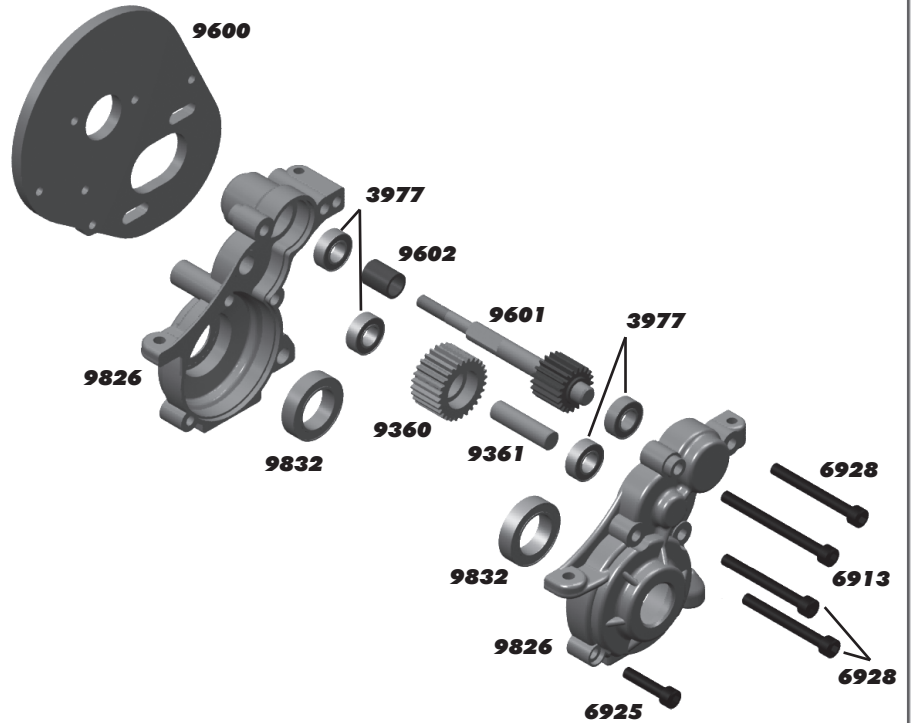

**:: Slipper Clutch**

6285	4-40 x 1/4 SHCS	12
6629	5-40 Locknuts	6
7460	Molded B4/T4 Gear Cover, black (Kit)	1
7461	Molded B4/T4 Gear Cover, clear	1
7486	V2 Slipper Spring and Washer	1
7485	V2 Slipper Hubs	2
9603	B4/T4 Slipper Pad	2
9650	75T 48P Spur Gear	1
9651	81T 48P Spur Gear	1
9652	78T 48P Spur Gear	1
9653	84T 48P Spur Gear	1
9654	87T 48P Spur Gear (Kit)	1



**:: Pinion Gears**

8253	16T 48P Pinion Gear - Brushed Kit	1	8267	30T 48P Pinion Gear	1
8254	17T 48P Pinion Gear	1	8268	31T 48P Pinion Gear	1
8255	18T 48P Pinion Gear - Brushless Kits	1	8269	32T 48P Pinion Gear	1
8256	19T 48P Pinion Gear	1	8270	33T 48P Pinion Gear	1
8257	20T 48P Pinion Gear	1	8271	34T 48P Pinion Gear	1
8258	21T 48P Pinion Gear	1	8272	35T 48P Pinion Gear	1
8259	22T 48P Pinion Gear	1			
8260	23T 48P Pinion Gear	1			
8261	24T 48P Pinion Gear	1			
8262	25T 48P Pinion Gear	1			
8263	26T 48P Pinion Gear	1			
8264	27T 48P Pinion Gear	1			
8265	28T 48P Pinion Gear	1			
8266	29T 48P Pinion Gear	1			

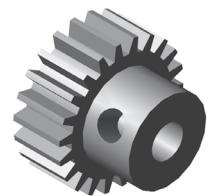

**:: Optional Ball Differential**

6573	Diff Thrust Washer & Bolt	2
6574	Precision Diff Thrust Balls, 5/64"	6
6575	Locking T-Nut, Diff Thrust Bolt, & Cover	1
6581	3/32" Carbide Diff Balls	12
6582	Diff Thrust Spring	1
6589	Ball Bearing, 5/32 x 5/16" unflanged	2
7664	Diff Gear 52T	1
7666	Diff Drive Rings, 2.60:1	2
7667	Diff Outdrive Hub, Right, 2.60:1	1
7668	Diff Outdrive Hub, Left, 2.60:1	1
7677	B4 / T4 / GT Diff Rebuild Kit	1
9574	B4 / T4 Transmission Case (left & right)	1
9852	SC10 Ball Diff Outdrives	1
9853	SC10 Complete Ball Differential	1

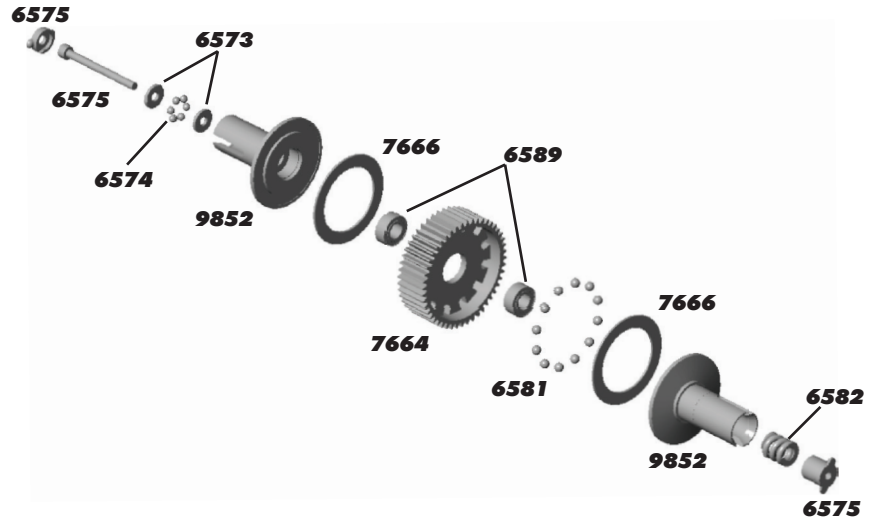

**:: Front Bumper / Shock Tower**

3897	Pivoting Body Mounts, Set	1
6272	Foam Ballend Dust Covers	28
6277	Ballstud .30 Silver (short)	4
6292	4-40 x 3/8" FHCS	6
6295	4-40 Nut	18
6332	Body Clips	6
6915	4-40 x 5/8" FHCS	6
6924	4-40 x 3/8" SHCS	6
6925	4-40 x 1/2" SHCS	6
7738	4-40 x 7/8" SHCS	6
9630	.030" Ballstud Washer	10
9816	SC10 Front Bumper, Front Bumper Brace, Skid Plate Set	1
9820	SC10 Front Body Mount	1
9821	SC10 Front Body Posts, Set	1
9825	SC10 Front Shock Tower	1

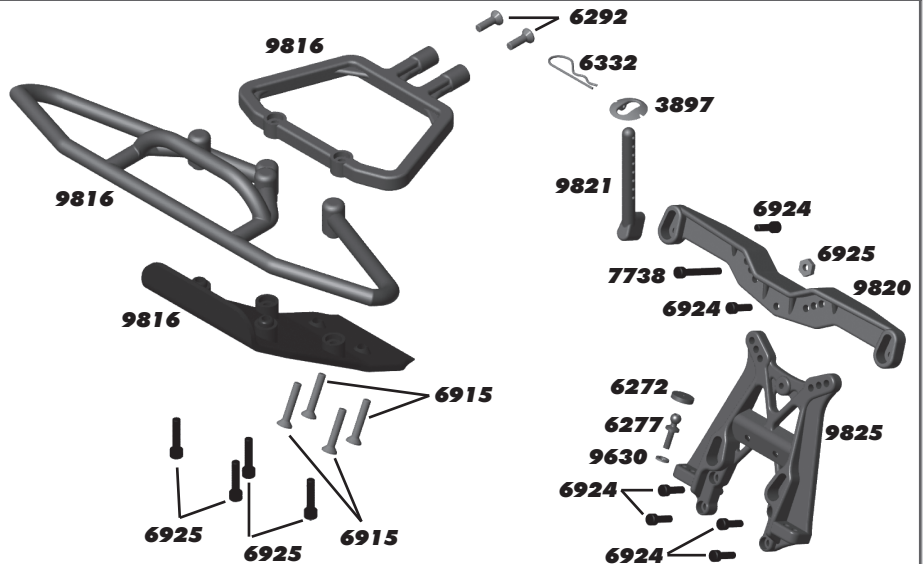

**:: Front Arms / Steering**

3977	Ball Bearing 3/16" x 3/8"	2
3983	Ballstud .30" Black (short)	6
4187	.030 Nylon Washers	12
4449	4-40x3/16 Aluminum Locknut	5
6272	Foam Ballend Dust Covers	28
6277	Ballstud .30 Silver (short)	4
6953	8-32 LP Locking Nut, Steel	6
7260	4-40 Plain Nut	12
7369	1/16" Unioversal Roll Pin	4
7446	T4 Front A-Arm (left & right)	Pr.
7922	30° Caster Blocks (left & right)	Pr.
9580	Caster Block Spacers, Set	1
9621	B4 Inner Hinge Pin Set	1
9622	B4 Outer Hinge Pin Set	1
9645	2-56 x 1/8" BHCS	8
9880	Steering Blocks, hex style	Pr.
9881	SC10 Front Axle Hex	Pr.
9882	C Clip	6
9883	SC10 Wheel Hex Adapters	4

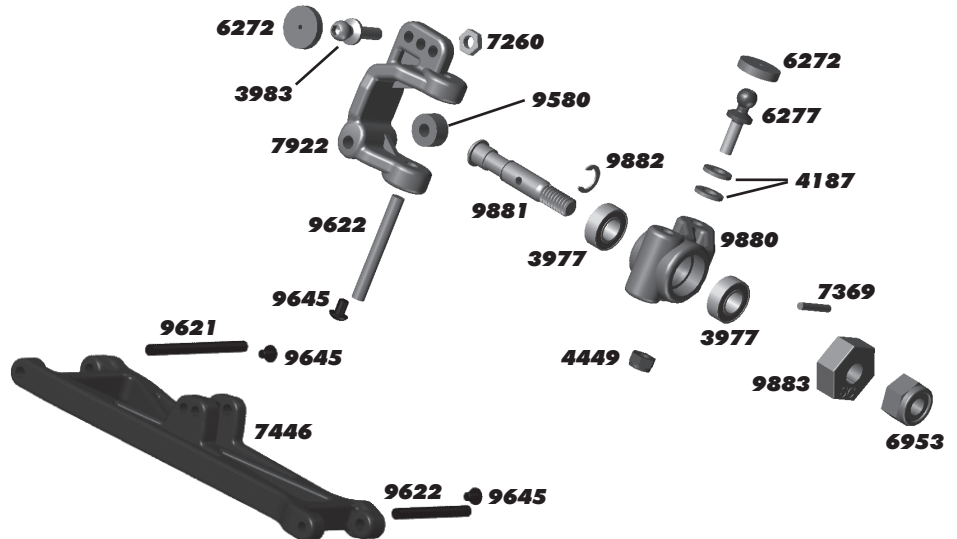

**:: Front Bulkhead**

2221	4-40 x 7/16" BHCS	6
3856	Steering Bushings, Set	1
6272	Foam Ball end Dust Covers	28
6276	Ballstud .20" Silver (short)	6
6925	4-40 x 1/2" SHCS	6
9566	B4 / T4 Top Plate	1
9610	Servo Saver / Steering Hardware	1
9640	B4 / T4 Steering Bolt, left & right	1
9657	B4 / T4 HD Servo Saver Spring	1
9659	B4 / T4 Steering Set. Includes Rack, Bellcrank, Servo Saver, Steering Brace	1

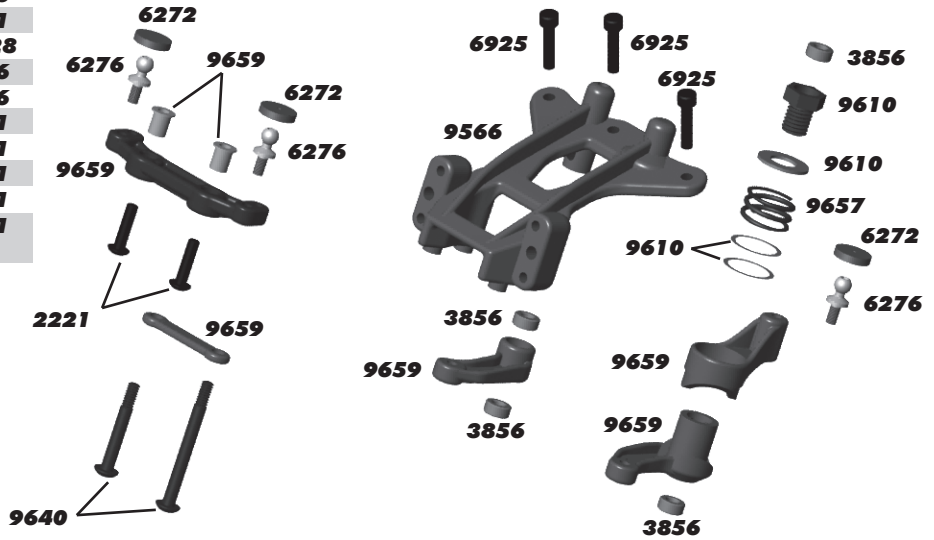

**:: Turnbuckles / Servo**

3981	Ballstud .20" Black (short)	6
6272	Foam Ballend Dust Cover	28
6292	4-40 x 3/8" FHCS	6
6917	4-40 x 3/8" BHCS	6
7101	Turnbuckle 2.80"	Pr.
7230	Ballcups, large	12
7253	Turnbuckle 2.62"	Pr.
7336	Servo Mount Set	1
7337	Gold Washer	4
9170	B4 / T4 Servo Link	1
9180	Servo Horns Set	1

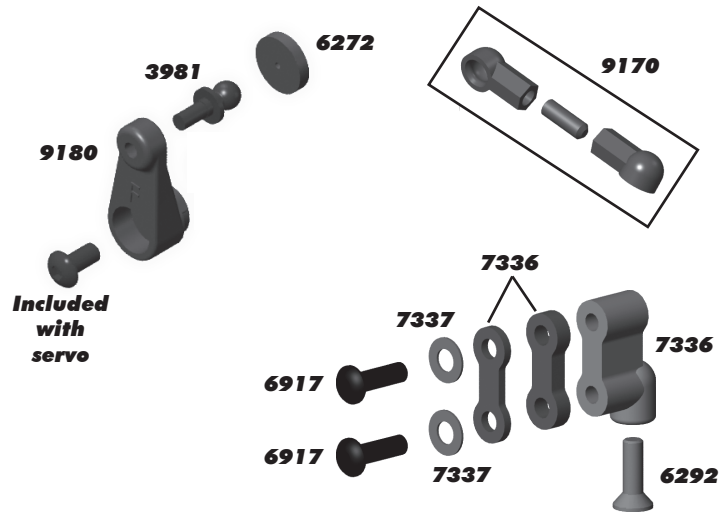
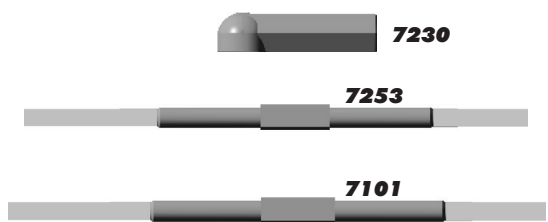

**:: Battery Strap**

9815	SC10 Foam Battery Spacer	1
9879	SC10 LiPo Battery Strap. Thumb Screws, and Set Screws	1

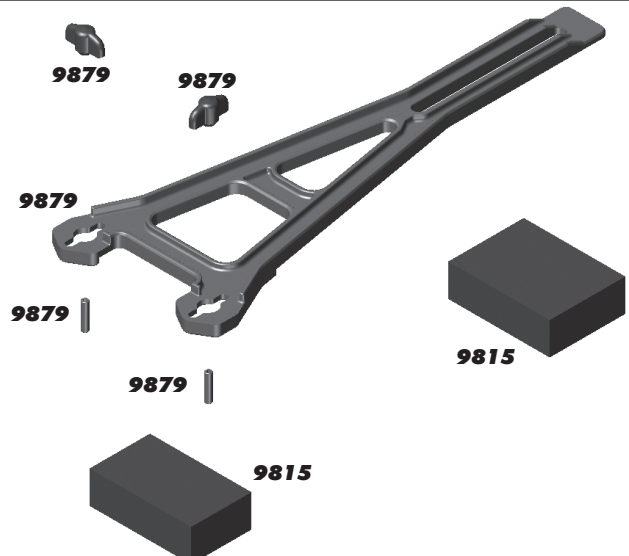

**:: Chassis**

3862	5-40 x 1/8" Set Screw	6
4334	2-56 x 5/16" BHCS	8
6272	Foam Ballend Dust Cover	28
6277	Ballstud .30" Silver (long)	4
6338	Antenna Tube (black)	1
6917	4-40 x 3/8" BHCS	6
6919	4-40 x 5/16" BHCS	6
6922	4-40 x 1/2" FHCS	6
6924	4-40 x 3/8" SHCS	6
7487	Arm Mounts, 2.5, 3, 3.5, 4	1
9269	5-40 x 1/2" FHCS	6
9563	B4 / T4 / GT2 Front Bulkhead	1
9564	RR / FR Hinge Brace	1
9621	B4 Inner Hinge Pin Set	4
9630	.030 Ballstud Washer	10
9643	5-40 x 7/16" SHCS	6
9645	2-56 x 1/8" BHCS	8
9818	SC10 Arm Mount / Chassis Plate	1
9819	SC10 Rear Motor Guard	1
9822	SC10 Nerf Bars	Pr.
9823	SC10 Chassis	1
9877	SC10 Receiver Box	1
9878	SC10 Receiver Box Seals	1

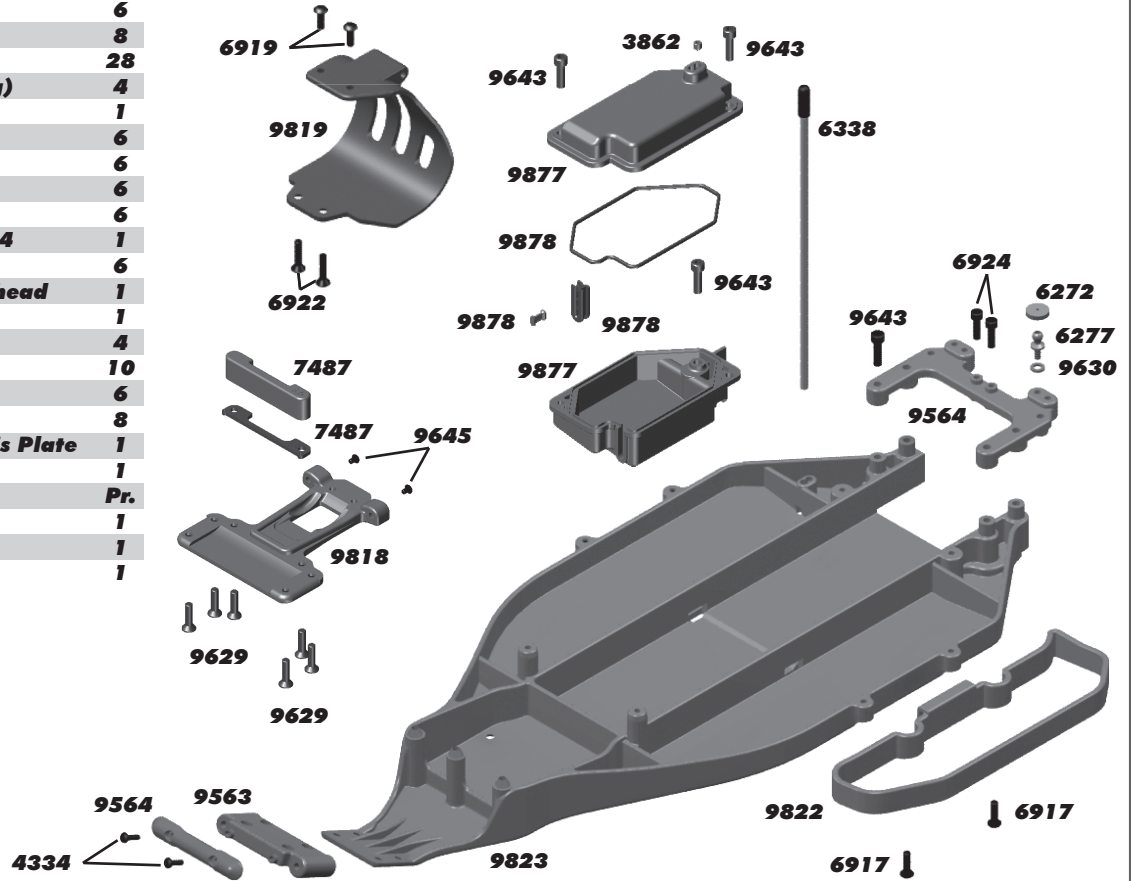

**:: Rear Arms / Hubs**

3977	Ball Bearing 3/16 x 3/8"	2
3983	Ballstud .30" Black (long)	6
4187	.030 Nylon Washers	12
5407	Red O-Ring	8
6272	Foam Ballend Dust Cover	28
6952	8-32 Locking Nut, steel	6
7260	4-40 Plain Nut	12
7369	1/16" Axle Roll Pins	4
7377	Axle Spacer Crush Tubes	2
7448	T4 Rear A-Arms	Pr.
7462	T4 / GT2 RTR Dogbone	1
9584	B4 / T4 RR Hub Carrier (left & right)	Pr.
9621	B4 Inner Hinge Pin Set	4
9622	B4 Outer Hinge Pin Set	6
9645	2-56 x 1/8" BHCS	8
9670	3/16" Rear Axle	1
9883	SC10 Wheel Hex Adapters	4

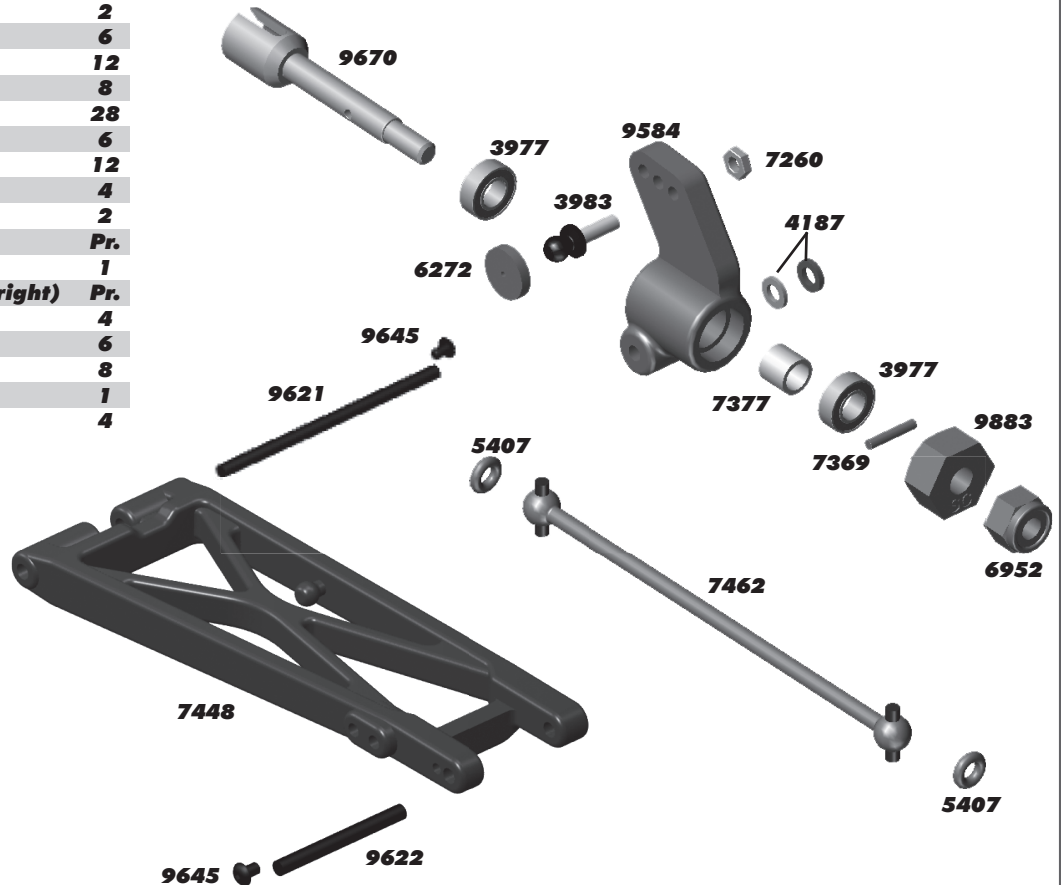

## :: Rear Shock Tower

<b>3897</b>	<b>Pivoting Body Mounts, Set</b>	<b>1</b>
<b>6332</b>	<b>Body Clips</b>	<b>6</b>
<b>6915</b>	<b>4-40 x 5/8" FHCS</b>	<b>6</b>
<b>6924</b>	<b>4-40 x 3/8" SHCS</b>	<b>6</b>
<b>6927</b>	<b>4-40 x 3/4" SHCS</b>	<b>6</b>
<b>7260</b>	<b>4-40 Plain Nut</b>	<b>12</b>
<b>9643</b>	<b>5-40 x 7/16" SHCS</b>	<b>6</b>
<b>9644</b>	<b>5-40 x 9/16" SHCS</b>	<b>6</b>
<b>9820</b>	<b>SC10 Body Mounts FR / RR</b>	<b>1</b>
<b>9821</b>	<b>SC10 Body Posts, Set</b>	<b>1</b>
<b>9824</b>	<b>T4 / SC10 Rear Shock Tower</b>	<b>1</b>

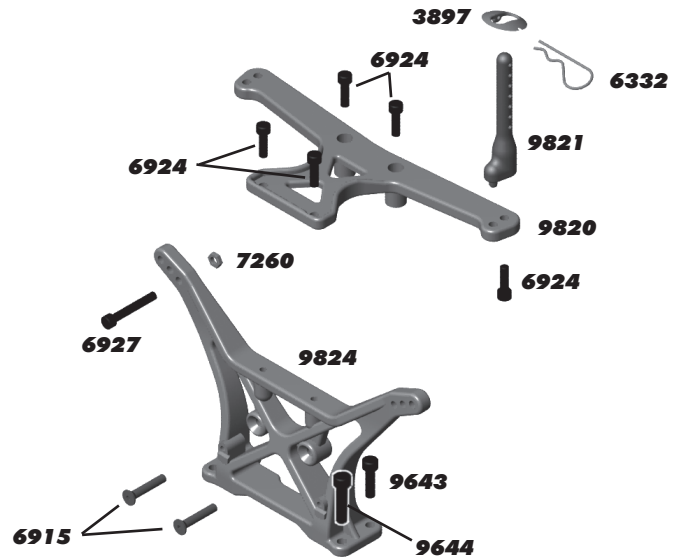

## :: Rear Bumper / Braces

<b>4449</b>	<b>4-40 x 3/16" Aluminum Locknut</b>	<b>5</b>
<b>6917</b>	<b>4-40 x 3/8" BHCS</b>	<b>6</b>
<b>6925</b>	<b>4-40 x 1/2" SHCS</b>	<b>6</b>
<b>9817</b>	<b>SC10 RR Bumper and Brace, Includes Bumper, Braces (left, right, upper, and lower),</b>	<b>1</b>
<b>9833</b>	<b>4-40 x 1 3/4" SHCS</b>	<b>6</b>
<b>89218</b>	<b>3x8mm washer</b>	<b>10</b>
<b>89430</b>	<b>Mud Flaps</b>	<b>Pr.</b>

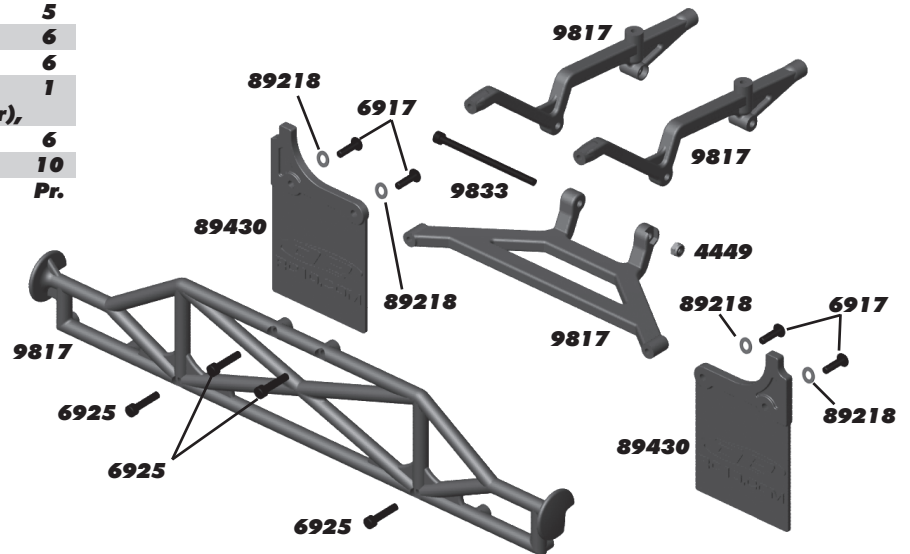

## :: Wheels / Tires

<b>9809</b>	<b>SC10 Tire with Foam Insert</b>	<b>2</b>
<b>9922</b>	<b>SC10RS Tires and Inserts</b>	<b>2</b>
<b>89413</b>	<b>1/8 Molded Tire Insert</b>	<b>2</b>
<b>91101</b>	<b>KMC Hex Wheels, Black</b>	<b>2</b>
<b>91102</b>	<b>KMC Hex Wheels, Silver</b>	<b>2</b>
<b>91103</b>	<b>KMC Hex Wheels, Chrome</b>	<b>2</b>
<b>91104</b>	<b>KMC Hex Wheels/Tire Black (Kit)</b>	<b>2</b>
<b>91105</b>	<b>KMC Hex Wheels/Tire Silver</b>	<b>2</b>
<b>91106</b>	<b>KMC Hex Wheels/Tire Chrome</b>	<b>2</b>

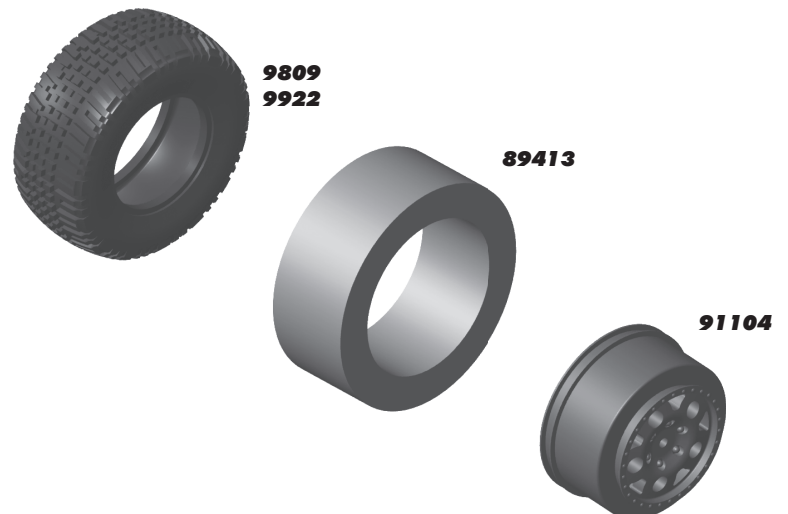

**:: Factory Team and Option Parts**

1283	FT T4 Ti Turnbuckle Set	1
1408	FT Ti Turnbuckle, 2.65" (blue) front steering	Pr.
1409	FT Ti Turnbuckle, 1" (sway bar) (blue)	Pr.
1417	FT Ti Turnbuckle, 2.80" (blue) front/rear camber	Pr.
1585	FT B4 Aluminum Trailing Axle, requires # 9581, 4187, Not for hex	Pr.
1598	FT Blue Aluminum Shock Caps, (blue) see also #6439	4
1654	FT Solid Axle Pins	4
1734	FT Blue Body Clip, 4 long, 6 short	10
1735	FT Blue Body Clip, long	4
1736	FT Blue Body Clip, short	6
1770	FT Milled Aluminum Motor Plate, (blue)	1
1777	Blue Aluminum Shock Ball Ends with Eyelets, Set	1
1778	FT Milled Aluminum Motor Plate, (black)	1
1779	FT Servo Mounts, blue aluminum	Pr.
1780	FT Blue Aluminum Threaded Shock Bushings	4
1781	FT Rear Shock Bushing (short)	4
1787	FT Battery Strap Thumb Screws, Set	1
3438	8-32 LP Locknuts (blue)	3
3971	Steering Rack Bearings	4
6416	Gold Shock Shaft, 1.32" stroke	1
6417	Gold Shock Shaft, 1.02" stroke	1
6439	FT Blue Aluminum Shock Caps, (blue) see also #1598	1
6443	Bleeder Shock Caps, 1/10	4
6463	Shock Pistons, Blank	8
6584	3/32" Ceramic Diff Balls	14
6906	Ball Bearing, PTFE Sealed 3/16 x 3/8"	2
6937	FT 4-40 Aluminum Locknuts (blue)	6
6943	FT 8-32 Aluminum Locknuts (blue)	6
7381	CVD/CVA Rebuild Kit	1
7447	T4 Front A-Arm, Carbon	Pr.
7449	T4 Rear A-Arm, Carbon	Pr.
7453	CVD Axle Bone T4 (black)	Pr.
7455	CVD Set T4	Pr.
7495	FT Vented V2 Slipper Hubs	2
7919	Caster Block 25 deg, (left & right)	Pr.
7933	Crush Tube (for use with FT Aluminum Hubs Only)	2
7935	.187 x .50 x .196 Bearing (for use with FT Aluminum Hubs Only)	2
7990	Aluminum Front Bulkhead (blue)	1
9565	B4 / T4 Chassis Brace, Hinge Pin Brace, Carbon	1
9567	B4 / T4 Top Plate, Carbon	1
9592	B4 / T4 Caster Block 20 deg, (left & right)	Pr.
9596	FT SC10 / T4 CVA Bones, requires #9755	Pr.
9598	CVD Axles B4, T4, SC10	Pr.
9600B	FT B4 / T4 Aluminum Motor Plate (blue)	1
9608	RR Axle Wheel Spacer (silver)	Pr.
9610B	B4 / T4 Blue Servo Saver Bolt	1
9635	B4 / T4 Sway Bar Kit.	1
9665	FT B4 / T4 Aluminum Hinge Pin Brace V2	1
9674	T4 Shiny CVD Dogbone, requires #9598	Pr.
9678	FT SC10 / T4 CVA Set	Pr.
9755	CVA Axle, Rear B44, B4, T4, SC10	Pr.
9789	SC10 / B4 FT Ti Front Axles, Set, requires # 9581, 4187 Not for hex	1
9795	Ti Nitride Ballstuds 4-40 x .20 - long	Pr.
9796	Ti Nitride Ballstuds 4-40 x .30 - long	Pr.
9797	Ti Nitride Ballstuds 4-40 x .40 - long	Pr.
9798	Ti Nitride Ballstuds 4-40 x .20 - short	Pr.
9799	Ti Nitride Ballstuds 4-40 x .30 - short	Pr.
9851	SC10 Battery Strap, Carbon	1
9864	FT Aluminum Hub, 0 deg (requires #7933, #7935)	Pr.
9865	FT Aluminum Hub, 0.5 deg (requires #7933, #7935)	Pr.
9866	FT Aluminum Hub, 1 deg (requires #7933, #7935)	Pr.
9867	FT Aluminum Hub, 1.5 deg (requires #7933, #7935)	Pr.
9872	FT Aluminum Hub Tower Set	1
9873	FT Aluminum Hub Tower C, carbon fiber	Pr.
9892	12mm Alum. Clamping Wheel Hex, Rear	2

**:: Factory Team and Option Parts cont.**

9917	Aluminum Hub A, Carbon	Pr.
9918	Aluminum Hub B, Carbon	Pr.
31237	CVA Pin Retaining Clip	Pr.
31286	FT Ballstud Washer, aluminum (1mm, 2mm)	4ea.
31327	VCS3 Shock Bottom Cap and O-Ring	2ea.
91170	FT High Torque Slipper Pad	2
91175	FT VTS Slipper Conversion	1
91176	VTS Slipper Housing	1
91177	VTS Slipper Pads	2
91178	VTS Slipper Plate	1
91179	FT VTS Slipper Hub, outer	1
91201	SC10B Front Arm	Pr.
91202	SC10B Front Shock Tower	1
91300	12X27.5mm FT Shock Bodies (front)	2
91302	12X36mm FT Shock Bodies (rear)	2
91303	12MM Shock Cap	2
91304	12MM Threaded Collar and O-Ring	2
91306	12MM 27.5 x 3 TiN Shock Shaft	1
91307	12MM 35 x 3 TiN Shock Shaft	1
91308	12MM Shock Pistons, (1.5, 1.6, 1.7)	4 ea.
91309	12MM Shock Rebuild Kit	1
91310	12MM Shock Spring Cups (+0mm, +5mm, +9mm)	4 ea.
91312	12MM Mounting Hardware	1
91315	12MM Big Bore Shock Kit (SC10 Front)	1
91317	12MM Big Bore Shock Kit (SC10 Rear)	1
91325	12MM Front SPRING BRN 2.85	Pr.
91326	12MM Front SPRING BLK 3.00	Pr.
91327	12MM Front SPRING GRN 3.15	Pr.
91328	12MM Front SPRING WHT 3.30	Pr.
91329	12MM Front SPRING GRY 3.45	Pr.
91330	12MM Front SPRING BLU 3.60	Pr.
91331	12MM Front SPRING YLW 3.75	Pr.
91332	12MM Front SPRING RED 3.90	Pr.
91333	12MM Front SPRING ORN 4.05	Pr.
91334	12MM Front SPRING PRL 4.20	Pr.
91335	12MM Rear SPRING BLK 1.90	Pr.
91336	12MM Rear SPRING GRN 2.00	Pr.
91337	12MM Rear SPRING WHT 2.10	Pr.
91338	12MM Rear SPRING GRY 2.20	Pr.
91339	12MM Rear SPRING BLU 2.30	Pr.
91340	12MM Rear SPRING YLW 2.40	Pr.
91341	12MM Big Bore Front Soft Spring Kit	1
91342	12MM Big Bore Front Medium Spring Kit	1
91343	12MM Big Bore Front Hard Spring Kit	1
91344	12MMv Big Bore Rear Soft Spring Kit	1
91345	12MM Big Bore Rear Medium Spring Kit	1
91346	FT 12MM Piston, 2 x 1.5mm, Tapered	4
91347	FT 12MM Piston, 2 x 1.6mm, Tapered	4
91348	FT 12MM Piston, 2 x 1.7mm, Tapered	4
91349	FT 12MM Piston, 3 x 1.4mm, Tapered	4
91350	FT 12MM Piston, 4 x 1.3mm, Tapered	4
91351	FT 12MM Piston, 2 x 1.6mm, Flat	4
91352	FT 12MM Piston, 3 x 1.4mm, Flat	4
91353	FT 12MM Piston, 4 x 1.3mm, Flat	4
91448	Shock Pivot Ball and Rod End	4
91449	12MM V2 Composite Shock Cap w/O-ring and bleeder screw	4
91577	FT 12x27.5mm FOX Shock Bodies with Genuine Kashima Coat, V2, threaded	2
91579	FT 12x36mm FOX Shock Bodies with Genuine Kashima Coat, V2, threaded	2
91635	12mm Shock Spring, 54mm, Green 3.75lbs	2
91636	12mm Shock Spring, 54mm, White 4.10lbs	2
91637	12mm Shock Spring, 54mm, Gray 4.45lbs	2
91639	12mm Shock Spring, 72mm, Green 2.20lbs	2
91640	12mm Shock Spring, 72mm, White 2.40lbs	2
91641	12mm Shock Spring, 72mm, Gray 2.60lbs	2

**:: Body and Decals**

9836	SC10 Body, Clear	1
9837	SC10 '09 Championship Body, Clear	1
9838	SC10 KMC (TM) Wheels Body, Painted	1
9850	SC10 Number Plate Decals	1
9856	SC10 '09 Body, Lucas Oil, Painted	1
9858	SC10 '09 Body, Pro Comp, Painted	1
9862	SC10 '09 Body, Rockstar / Makita, Painted	1
9863	SC10 '09 Decals, Rockstar / Makita	1
9876	SC10 Contender Body, Clear	1
9926	SC10 Toyota Racing Body, Clear	1
91191	SC10 Contender Body, Lucas Oil	1
91192	SC10 Contender Body, AE Team	1

**:: Reedy Electronics**

907	540-SL4 3300kv 4-pole Sensorless Brushless Motor	1
26169	0712MG 7kg Metal Gear Servo	1
26170	1415MG 15kg Metal Gear Servo	1
27100	RS1206 Digital HV Hi-Speed Competition Servo	1
27101	RT1508 Digital HV Hi-Torque Competition Servo	1
29184	SC800-BL/SC1000-BL/SC1000-DB/SC600-BL Switch	1
29185	SC600-BL Brushless ESC	1
29186	SC600-BL Fan	1

**:: XP Electronics / Electronic Accessories**

29166	XP DS1313 Digital Servo	1
29167	XP DS1015 Digital Servo	1
29203	AE XP120 2.4GHz Radio System	1
29204	AE XP-R4 2.4GHz 4CH Receiver	1
29261	ESS-One Plus Engine Sound System	1
29265	XP Police Light Bar, 1:10 scale	1
29266	XP LED RC Light Kit (12 LEDs)	1
29267	XP LED Roof Light Kit (4 LEDs)	1
29268	XP LED Roof Light Kit (6 LEDs)	1
29272	XP 5 LED Aluminum Light Bar, 88mm	1
29273	XP 7 LED Aluminum Light Bar, 120mm	1
29274	XP 10 LED Aluminum Light Bar, 170mm	1
29275	XP LED Light Bar Hardware	1

**:: Reedy Batteries**

302	AA Alkaline 1.5V (4)	1
681	Wolfpack 2400mAh 7.2V w/T-Plug connector	1
682	Wolfpack 3000mAh 7.2V w/T-Plug connector	1
683	Wolfpack 3600mAh 7.2V w/T-Plug connector	1
684	Wolfpack 4200mAh 7.2V w/T-Plug connector	1
751	Wolfpack LiPo 3300mAh 30C 7.4V w/T-Plug	1
752	Wolfpack LiPo 4000mAh 35C 7.4V w/T-Plug	1
753	Wolfpack LiPo 5400mAh 35C 7.4V w/T-Plug	1
754	Wolfpack LiPo 7500mAh 30C 7.4V w/T-Plug	1
755	Wolfpack LiPo 4500mAh 35C 11.1V w/T-Plug	1

**:: Reedy Chargers / Accessories**

616	423-S AC 35W Compact Balance Charger	1
616CN	423-S Charger/ 3000mAh 7.2V NiMH Battery	1
616CL	423-S Charger/ 3300mAh 7.4V LiPo Battery	1
27200	1216-C2 Dual AC/DC Competition Battery Charger	1
27201	324-S AC LiPo/LiFe Compact Balance Charger	1
27201C2	324-S Charger w/3300mAh 7.4V LiPo Battery	1
27201C3	324-S Charger w/4500mAh 11.1V LiPo Battery	1
27220	7-in-1 Universal Charge Lead (4mm)	1
27221	T-plug Charge Lead (4mm)	1

**:: Kicker Audio**

29269	KICKER KPw Wireless Speaker System, (black)	1
29270	KICKER KPw Wireless Speaker System, (white)	1

**:: Lubes & Adhesives / Decals / Misc.**

1105	FT Green Slime Shock Lube	1
1596	FT Locking Adhesive	1
1597	FT Tire Adhesive, medium	1
6588	Black Grease - 4cc	1
6591	S.Diff Lube - 4cc	1
6636	Silicone Grease - 4cc	1
6727	Servo Tape	2
726	Reedy 2016 Sticker Set	1
3840	2016 Team Associated Decals	1
9787	FT Chassis Protective Sheet	1





**:: Tools**

1111	FT Turnbuckle Wrench	1
1113	12mm Big Bore Shock Tool	1
1114	FT Dual Turnbuckle Wrench	1
1449	FT Off Road Ride Height Gauge	1
1500	FT 1.5mm Hex Driver	1
1501	FT 2.0mm Hex Driver	1
1502	FT 2.0mm Ball Hex Driver	1
1503	FT 2.5mm Hex Driver	1
1504	FT 2.5mm Ball Hex Driver	1
1506	FT 5.0mm Hex Driver	1
1507	FT 5.5mm Nut Driver	1
1508	FT 7.0mm Nut Driver	1
1511	FT 2.0mm Hex Replacement Tip	1
1512	FT 2.0mm Ball Hex Replacement Tip	1
1513	FT 2.5mm Hex Replacement Tip	1
1514	FT 2.5mm Ball Hex Replacement Tip	1
1515	FT 3.0mm Hex Replacement Tip	1
1518	FT Hex Driver Tool Set, 3pc	1
1519	FT Hex/Nut Driver Tool Set, 5pc	1
1541	FT Hex Driver Set, (7 pcs)	1
1545	FT 5/64" Blue Hex Driver	1
1546	FT 3/32" Gold Hex Driver	1
1554	FT Silver Spring Hook Tool	1
1567	FT 8mm Gold Nut Driver	1
1568	Factory Team 5.5mm Short Nut Driver	1
1569	Factory Team 7mm Nut Driver, T-Handle	1
1570	Factory Team 7.0mm Short Nut Driver	1
1571	FT 1/8 Wheel Nut Wrench	1
1590	FT 3/32" Gold Ball Hex Driver	1
1592	FT Ball Hex Driver Set, (3 pcs)	1
1655	FT 8-Piece 1/4" Hex Drive Set	1
1656	FT 1/4" Hex Drive Handle, without tips	1
1657	FT 1/4" Hex Drive .050" Tip	1
1658	FT 1/4" Hex Drive 1/16" Tip	1
1659	FT 1/4" Hex Drive 5/64" - 2.0mm Tip	1
1660	FT 1/4" Hex Drive 3/32" Tip	1
1661	FT 1/4" Hex Drive 1.5mm Tip	1
1662	FT 1/4" Hex Drive 2.5mm Tip	1
1663	FT 1/4" Hex Drive 3/16" Nut Driver Tip	1
1664	FT 1/4" Hex Drive 1/4" Nut Driver Tip	1
1665	FT 1/4" Hex Drive 11/32" Nut Driver Tip	1
1666	FT 1/4" Hex Drive 5.5mm Nut Driver Tip	1
1667	FT 1/4" Hex Drive 7.0mm Nut Driver Tip	1
1668	FT 1/4" Hex Drive 8.0mm Nut Driver Tip	1
1669	FT 1/4" Hex Drive 5/64" - 2.0mm Ball End Tip	1
1670	FT 1/4" Hex Drive 3/32" Ball End Tip	1
1671	FT 1/4" Hex Drive Standard Screwdriver Tip	1
1672	FT 1/4" Hex Drive Phillips Screwdriver Tip	1
1673	FT 1/4" Hex Drive 2.5mm Ball End Tip	1
1674	FT 1/4" 5 Piece Power Tool Tips Set (5/64-2.0mm, 1.5mm, 2.5mm, 5/64"- 2.0mm ball, 2.5mm ball)	1
1675	FT Shock Shaft Pliers	1
1679	FT T-Handle Ratchet Driver	1
1719	FT Camber + Track Width Tool	1
1737	FT Body Scissors	1
3718	12 Inch Nylon Wire Ties	12
3719	6 Inch Nylon Wire Ties	12
3720	8 Inch Nylon Wire Ties	12
3987	Composite Droop Gauge	1
6429	Shock Building Tool	1
6956	Molded Tools, Set	1
7709	4 Inch Nylon Wire Ties	12

**:: Apparel / Promotional**

SP11*	2016 Worlds T-Shirt - Blue - (S, M, L, XL-5XL)	1
SP12*	2016 Worlds T-Shirt - Black - (S, M, L, XL-5XL)	1
SP13**	AE Lite Jacket - Black - (S, M, L, XL, 2XL)	1
SP14**	AE 2015 Worlds T-Shirt - Blue (S, M, L, XL-5XL)	1
SP15**	AE 2015 Worlds T-Shirt - Black (S, M, L, XL-5XL)	1
SP16**	AE 2015 Worlds Hoodie - Black (S, M, L, XL-3XL)	1
SP17**	AE INT'L T-Shirt - Black (S, M, L, XL-5XL)	1
SP18**	AE INT'L T-Shirt - White (S, M, L, XL-5XL)	1
SP19**	AE INT'L Hoodie - Black (S, M, L, XL-3XL)	1
SP20	AE Patch Trucker Hat	1
SP23**	AE Splash T-shirt - Black (S, M, L, XL-5XL)	1
SP24**	AE Splash T-shirt - Blue (S, M, L, XL-5XL)	1
SP29	Team Associated Countertop / Setup Mat	1
SP30	Team Associated Pit Mat	1
SP31	Reedy Countertop / Setup Mat	1
SP38	Reedy Trucker Hat	1
SP71**	AE Winter Jacket - Black (S, M, L, XL, 2XL)	1
SP90**	AE Retro T-shirt, Blue (S, M, L, XL-5XL)	1
SP110*	Reedy R-Powered T-Shirt - Black (S, M, L, XL-3XL)	1
SP111*	Reedy W15 Sweatshirt - Black (S, M, L, XL-3XL)	1
SP112*	Reedy Medallion T-Shirt - Black (S, M, L, XL-3XL)	1
SP113*	AE Worlds Car Retro T-Shirt - White (S, M, L, XL-3XL)	1
SP114*	Circuit T-Shirt - Black (S, M, L, XL, 2-3XL)	1
SP408	AE Worlds Hat - Black Snap Back	1
SP421S	AE 2012 Hat, Black, Flat Bill, S/M	1
SP421L	AE 2012 Hat, Black, Flat Bill, L/XL	1
SP422S	AE 2012 Hat, Black, Curved Bill, S/M	1
SP422L	AE 2012 Hat, Black, Curved Bill, L/XL	1
SP423S	AE 2012 Hat, White, Flat Bill, S/M	1
SP423L	AE 2012 Hat, White, Flat Bill, L/XL	1
SP424S	AE 2012 Hat, White, Curved Bill, S/M	1
SP424L	AE 2012 Hat, White, Curved Bill, L/XL	1
SP425	FT Fluid Carrier	1
715	Reedy 2009 Track Banner	1
110684	Team Associated Track Banner	1
110685	Team Associated Cloth Banner	1

\*\* Use part number plus the desired size when ordering!

**:: Notes**

Blank area for notes.

**:: Notes****:: Contact Information**

**Associated Electrics, Inc.  
26021 Commercentre Drive  
Lake Forest, CA 92630-8853 USA**

**Check out the following web sites for all  
of our electric kits, current products, new  
releases, setup help, tips, and racing info!**

**<http://www.TeamAssociated.com>**

**<http://www.RC10.com>**

**<http://twitter/Team Associated>**

**<http://bit.ly/AEonFacebook>**

**call: (949) 544-7500**

**fax: (949) 544-7501**

### Front Suspension

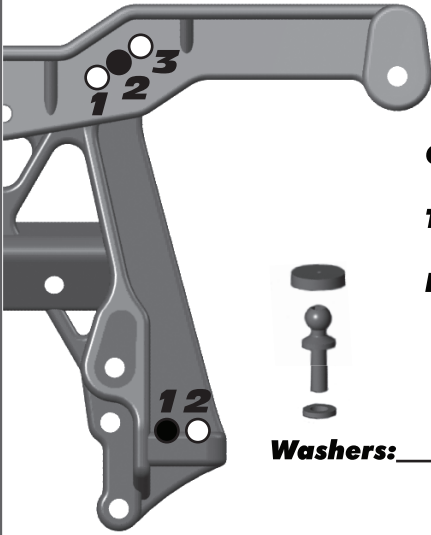

Camber: -1°

Toe: 0°

Ride Height: arms level



Washers: 1

Bump Steer Spacers: 2

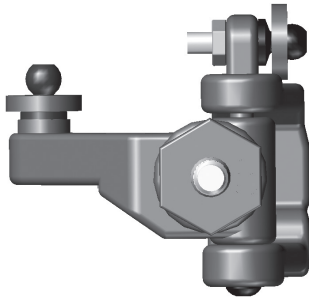

Caster:

- 20°   
 25°   
 30°

ABC



### Rear Suspension

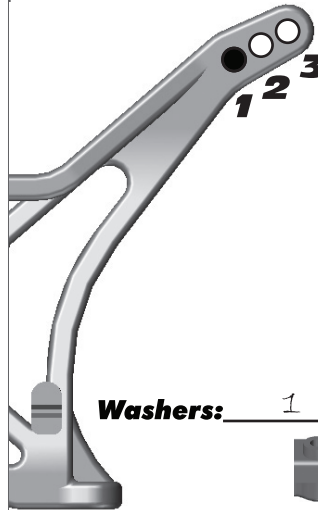

Camber: 0°

Ride Height: bones level

Anti-Squat: 2°

Toe: 3°

Washers: 1

Anti Roll Bar:

- None   
 Black (soft)   
 Silver (med)   
 Gold (hard)

Rear Hub Carriers:

- Std 0°   
 0.5°   
 1°   
 1.5°

Drivetrain:

- Dog Bones   
 CVD   
 CVA

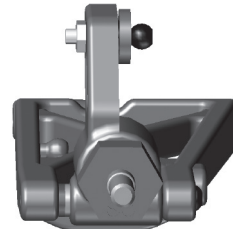

Wheelbase:

- Long   
 Medium   
 Short

Rear Hub Tower: std

ABC



### Front Shocks

Spring: gold Piston: #3  
 Shock Fluid: 30wt Limiter: 5 thin  
 Rebound: \_\_\_\_\_ Bladder  Emulsion

### Rear Shocks

Spring: green Piston: #1  
 Shock Fluid: 30wt Limiter: 2 thin  
 Rebound: \_\_\_\_\_ Bladder  Emulsion

### Electronics

Motor & Wind: \_\_\_\_\_  
 Pinion: \_\_\_\_\_  
 Spur Gear: 87  
 Batteries: \_\_\_\_\_  
 Battery Placement: Front  Middle  Back   
 Other

Radio: XP 2.4 GHz  
 Throttle / Brake e.p.a: \_\_\_\_\_  
 Throttle / Brake expo: \_\_\_\_\_  
 Servo: \_\_\_\_\_ Steering Expo: \_\_\_\_\_  
 ESC: \_\_\_\_\_  
 ESC Profile: \_\_\_\_\_

### Differentials

Gear Diff:  black grease  
 Ball Diff:

### Other

Body Type: SC10 09' Championship Body  
 Body Notes: \_\_\_\_\_

### Front Tires

Tire: standard Compound: standard  
 Insert: standard Wheel: KMC Hex - black  
 Notes: \_\_\_\_\_

### Rear Tires

Tire: standard Compound: standard  
 Insert: standard Wheel: KMC Hex - black  
 Notes: \_\_\_\_\_

### Race and Vehicle Comments

Qualify: \_\_\_\_\_ Main: \_\_\_\_\_ Finish: \_\_\_\_\_ TQ: \_\_\_\_\_  
 Comments: \_\_\_\_\_

### Track Info

- Smooth:  Bumpy:  Blue Groove:   
 Traction:  High:  Medium:  Low:   
 Soft Dirt:  Grass:  Clay:  Wet:   
 Dusty:  Other: \_\_\_\_\_

### Front Suspension

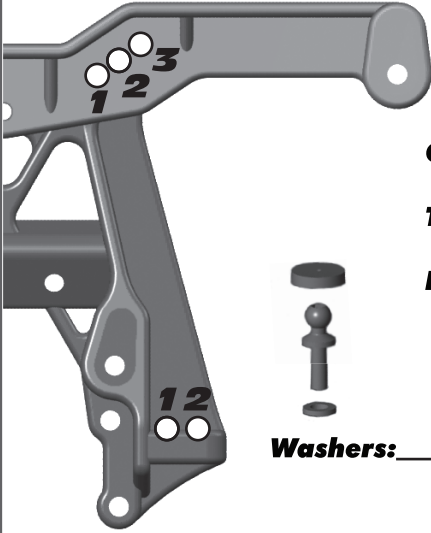

**Camber:** \_\_\_\_\_  
**Toe:** \_\_\_\_\_  
**Ride Height:** \_\_\_\_\_

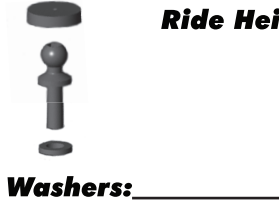

**Bump Steer Spacer:** \_\_\_\_\_

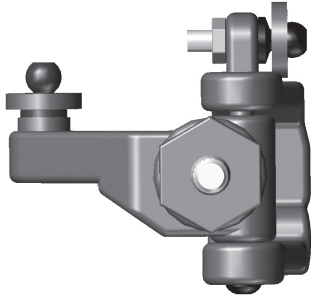

**Caster:**  
 20°   
 25°   
 30°

**ABC**

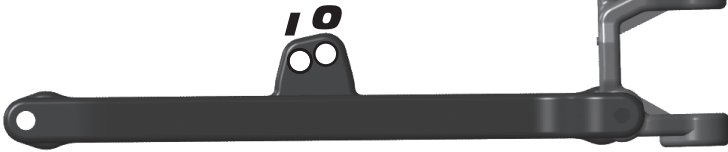

### Rear Suspension

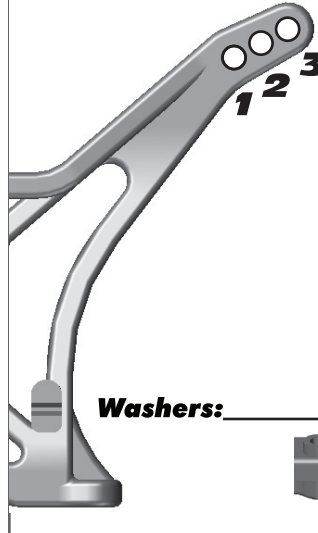

**Camber:** \_\_\_\_\_  
**Ride Height:** \_\_\_\_\_  
**Anti-Squat:** \_\_\_\_\_  
**Toe:** \_\_\_\_\_



**Anti Roll Bar:**  
 None   
 Black (soft)   
 Silver (med)   
 Gold (hard)

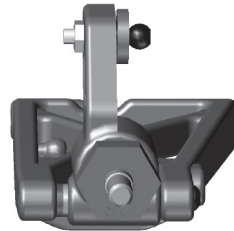

**Drivetrain:**  
 Dog Bones   
 CVD   
 CVA

**Rear Hub Carriers:**  
 Std 0°   
 0.5°   
 1°   
 1.5°

**Wheelbase:**  
 Long   
 Medium   
 Short

**Rear Hub Tower:** \_\_\_\_\_

**ABC**



### Front Shocks

**Spring:** \_\_\_\_\_ **Piston:** \_\_\_\_\_  
**Shock Fluid:** \_\_\_\_\_ **Limiters:** \_\_\_\_\_  
**Rebound:** \_\_\_\_\_ **Bladder**  **Emulsion**

### Rear Shocks

**Spring:** \_\_\_\_\_ **Piston:** \_\_\_\_\_  
**Shock Fluid:** \_\_\_\_\_ **Limiters:** \_\_\_\_\_  
**Rebound:** \_\_\_\_\_ **Bladder**  **Emulsion**

### Electronics

**Motor & Wind:** \_\_\_\_\_  
**Pinion:** \_\_\_\_\_  
**Spur Gear:** \_\_\_\_\_  
**Batteries:** \_\_\_\_\_  
**Battery Placement:** Front  Middle  Back   
 Other

**Radio:** \_\_\_\_\_  
**Throttle / Brake e.p.a.:** \_\_\_\_\_  
**Throttle / Brake expo:** \_\_\_\_\_  
**Servo:** \_\_\_\_\_ **Steering Expo:** \_\_\_\_\_  
**ESC:** \_\_\_\_\_  
**ESC Profile:** \_\_\_\_\_

### Differentials

**Gear Diff:**   
**Ball Diff:**

### Other

**Body Type:** \_\_\_\_\_  
**Body Notes:** \_\_\_\_\_

### Front Tires

**Tire:** \_\_\_\_\_ **Compound:** \_\_\_\_\_  
**Insert:** \_\_\_\_\_ **Wheel:** \_\_\_\_\_  
**Notes:** \_\_\_\_\_

### Rear Tires

**Tire:** \_\_\_\_\_ **Compound:** \_\_\_\_\_  
**Insert:** \_\_\_\_\_ **Wheel:** \_\_\_\_\_  
**Notes:** \_\_\_\_\_

### Race and Vehicle Comments

**Qualify:** \_\_\_\_\_ **Main:** \_\_\_\_\_ **Finish:** \_\_\_\_\_ **TQ:** \_\_\_\_\_  
**Comments:** \_\_\_\_\_  
 \_\_\_\_\_  
 \_\_\_\_\_

### Track Info

**Smooth:**  **Bumpy:**  **Blue Groove:**   
**Traction:**  **High:**  **Medium:**  **Low:**   
**Soft Dirt:**  **Grass:**  **Clay:**  **Wet:**   
**Dusty:**  **Other:** \_\_\_\_\_



**Associated Electrics, Inc.  
26021 Commercentre Dr.  
Lake Forest, CA 92630 USA**

**<http://www.TeamAssociated.com>**

**<https://www.RC10.com>**

**[https://twitter/Team\\_Associated](https://twitter/Team_Associated)**

**<https://bit.ly/AEonFacebook>**

**call: (949) 544-7500 - fax: (949) 544-7501**

**Check out the following web sites for all of our kits,  
current products, new releases, setup help, tips, and racing info!  
[www.TeamAssociated.com](http://www.TeamAssociated.com) - [www.RC10.com](http://www.RC10.com)**